

Visit various sections of the institute and location of electrical installations

Objectives: At the end of this exercise you shall be able to

- visit the various sections/trade in your ITI and draw the layout of your ITI
- record the telephone numbers of the ITI office, hospitals, police station and fire station
- draw the layout of your section
- identify the locations that have electrical installations.

PROCEDURE

TASK 1: Visit various sections of the ITI and draw the layout of your ITI

Instructor will lead the new trainees to various sections of the ITI.

- | | |
|---|--|
| <ol style="list-style-type: none"> 1 Visit the various sections in your ITI and identify the sections of the ITI. List the trades and record it in your note book. 2 Collect the information about the staff members in each trade. 3 Identify the location of the ITI with details about the railway and bus stations in the locality and note down the list of bus route numbers which ply near the ITI. | <ol style="list-style-type: none"> 4 Collect the telephone numbers of the ITI office, nearest hospitals, nearest police station and the nearest fire station and record. 5 Draw the layout of your ITI showing various trades. |
|---|--|

Note :A Sample layout of the ITI (Fig 1) is given for your reference. Now draw the new layout of your ITI, with the trades/sections.

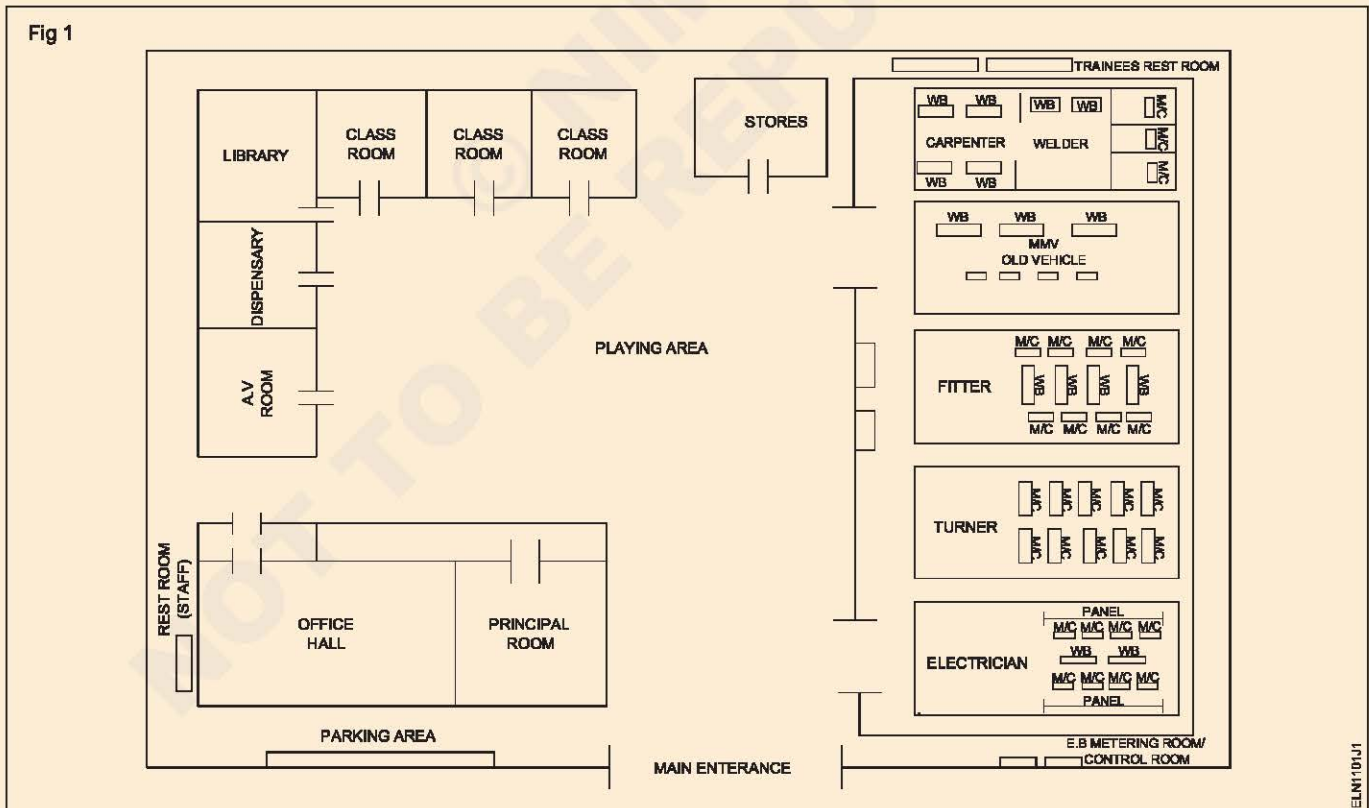

ELN1/01/1

TASK 2: Draw the layout of your section in the ITI

- 1 Draw the plan of your section to a suitable scale in a separate sheet of paper (A4 size).
- 2 Take the length and the breadth measurements of machine foundations, work benches, panels, wiring cubicles, doors, windows, furniture, etc.
- 3 Draw the layout of the machines, work benches, panels and furniture.

The section plan should be in the same scale as in step 1 as per the actual placement of the machine foundations, panels, furniture, work benches etc.

Note : The sample layout of a typical electrician trade section is given for your reference (Fig 2). You have to draw your section's is layout using the sample as reference.

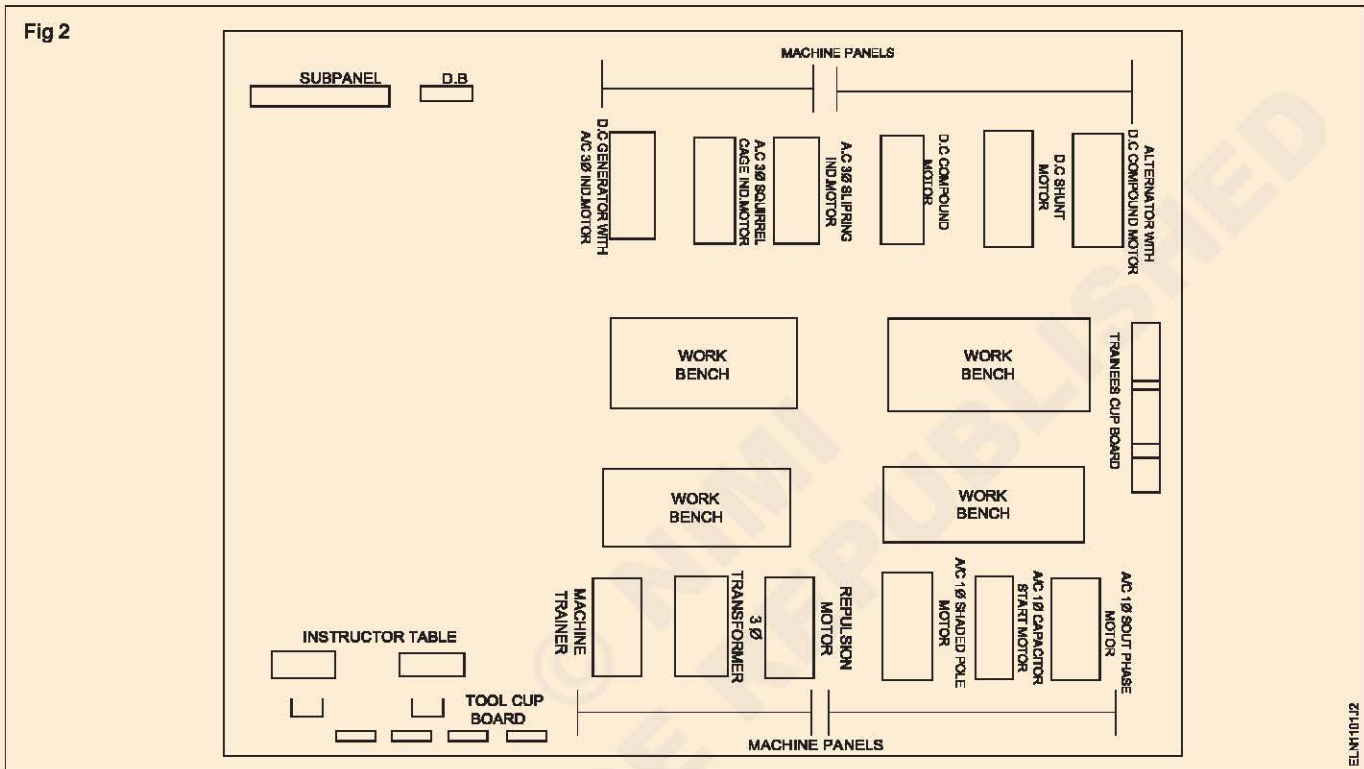

TASK 3: Identify the locations of Power installations

- 1 Identify the main switch and mark its position in the layout. (Fig 3)
- 2 Identify each of the sub-main switches, the area of control in the section and mark them on the layout.
- 3 Identify 3 or 4 spots in various locations of the electrician sections layout and identify the respective sub-main switches.
- 4 Practice switching 'off' the control switches, depending upon the area of control, imagining that victim are electrocuted in a specific location/spot.

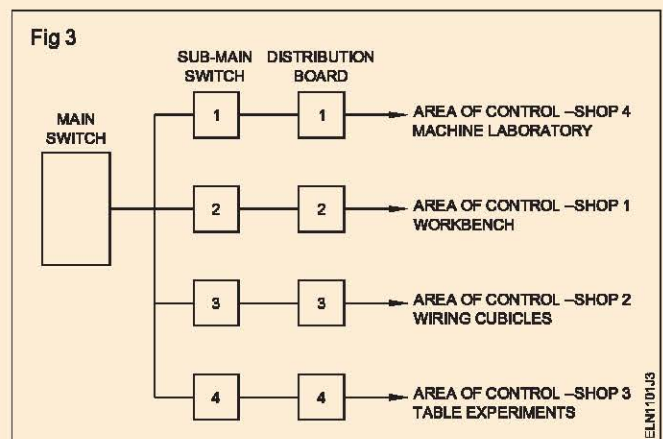

Identify safety symbols and hazards

Scan the QR Code to view the video for this exercise

Objectives: At the end of this exercise you shall be able to

- identify the safety symbols from the chart and their basic categories
- write their meaning and description mentioning where they are used
- read and interpret different types of occupational hazards from the chart.

Requirements**Materials**

- Basic safety signs chart - 1 No.
- Occupational hazards chart - 1 No.
- Road safety signs and traffic signal chart - 1 No.





PROCEDURE





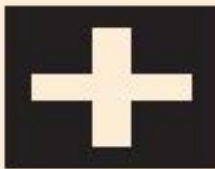

TASK 1: Identify safety symbols and interpret what they mean with the help of their colour and shape

Instructor may provide charts with various safety signs for the road safety signs in traffic signals. Then, explain the categories meaning and colour. Ask the trainees to identify the signs and record it in Table 1.

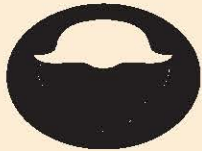
- 1 Identify the signs and their categories from the chart.
- 2 Write the name, categories, meaning and description of each sign and its place of use in Table 1.

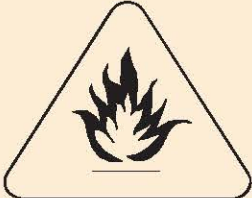
Table 1

No.	Safety signs	Name of the sign and category	Place of use
1			
2			
3			
4			
5			

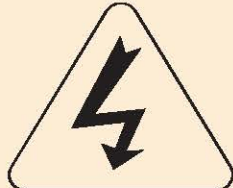
No.	Safety signs	Name of the sign and category	Place of use
6			
7			
8			
9			
10			
11			
12			
13			

TASK 2 : Read and interpret the different types of personal protective equipment (PPE) from the chart

Instructor may brief the various types of occupational hazards and their causes.

2 Complete the details and get it checked by your instructor.

1 Identify the occupational hazard matching it to the corresponding situation with the given potential in Table 2.

Table 2

Sl.No.	Source or potential harm	Type of occupational hazard
1	Noise	
2	Explosive	
3	Virus	
4	Sickness	
5	Smoking	
6	Non-control device	
7	No earthing	
8	Poor housekeeping	

Preventive measures for electrical accidents and practice steps to be taken in such accidents



Scan the QR Code to view the video for this exercise

Objectives: At the end of this exercise, you shall be able to

- practice and follow preventive safety rules to avoid electrical accidents
- rescue the electric shock victim

Requirements

Materials

- | | | | |
|--|---------|----------------|---------|
| ▪ Heavy insulated screwdriver 200 mm | - 1 No. | ▪ Wooden stool | - 1 No. |
| ▪ Electrical safety chart (or) display | - 1 No. | ▪ Ladder | - 1 No. |
| ▪ Gloves | - 1 No. | ▪ Safety belt | - 1 No. |
| ▪ Rubber mat | - 1 No. | | |

PROCEDURE

TASK 1: Practice and follow preventive safety rules to avoid electrical accidents

- 1 Do not work on live circuits. If unavoidable use rubber gloves or rubber mats.
- 2 Do not touch bare conductors.
- 3 Stand on a wooden stool or an insulated ladder while repairing live Power circuits/appliances or replacing fused bulbs.
- 4 Stand on rubber mats while working, operating switch panels, control gears, etc.
- 5 Always use safety belts while working on poles or high-rise points.
- 6 Use screwdrivers with wooden or PVC insulated handle when working on electrical circuits.
- 7 Replace (or) remove fuses only after switching off the circuit switches.
- 8 Do not stretch your hands towards any moving part of the rotating machine and around moving shafts.
- 9 Do not connect earthing to the water supply Power lines.
- 10 Discharge static voltage in HV lines/equipment and capacitors before working on them.
- 11 Keep the workshop floor clean and tools in good condition.

TASK 2: Rescue the electric shock victim

- 1 Switch OFF the power or remove the plug or wrench the cable free.
- 2 Move the victim from contact with the live conductor by using dry non-conducting materials like wooden bars. (Fig 1 & 2)
- 5 Keep the victim warm and comfortable. (Fig 3)
- 6 Send someone to call the doctor, in case of electric burns.

Avoid direct contact with the victim. Wrap your hands with dry material if rubber gloves are not available. If you are uninsulated, do not touch the victim with your bare hands.

- 3 Keep the patient warm and at mental rest.

Ensure that there is good air circulation. Seek help to shift the patient to a safer place. If the victim is aloft, take steps to prevent him from falling.

- 4 Loosen the clothing near the neck, chest and waist and place the victim in a relaxed position, if the victim is unconscious.

If the victim has Power burns due to shock, it may be very painful and is dangerous. If a large area of the body is burnt do not give treatment. Give first-aid as given in step 8

- 7 Cover the burnt area with pure running water.
- 8 Clean the burnt area using a clean cloth/cotton.

In case of severe bleeding

- 9 Lay the patient flat.
- 10 Raise the injured part above the body level. (If possible)
- 11 Apply pressure on the wound, as long as necessary, to stop the bleeding. (Fig 4)

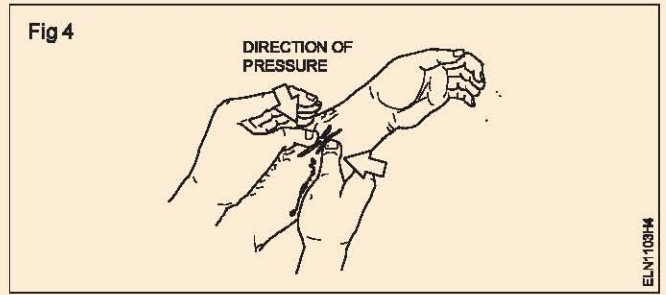
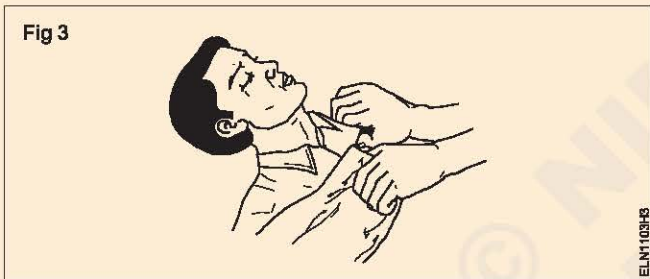
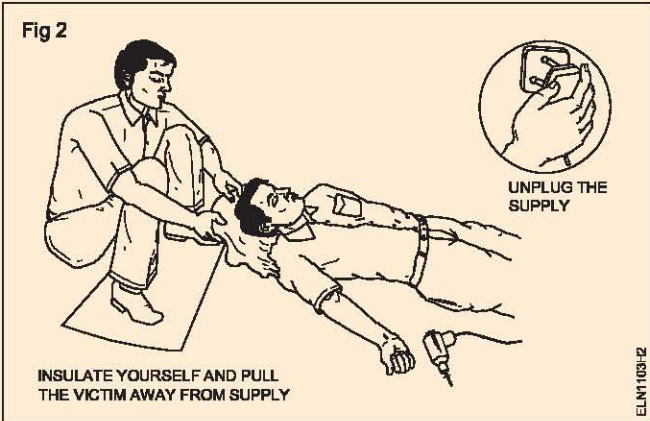
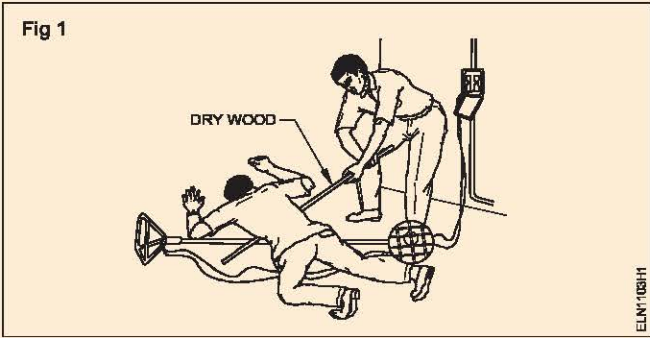

12 cover the injured area with a clean pad and bandage firmly, if it is a large wound. (Fig 5)

If bleeding is severe, use more than one dressing.

13 initiate right methods of artificial respiration, if the person is unconscious

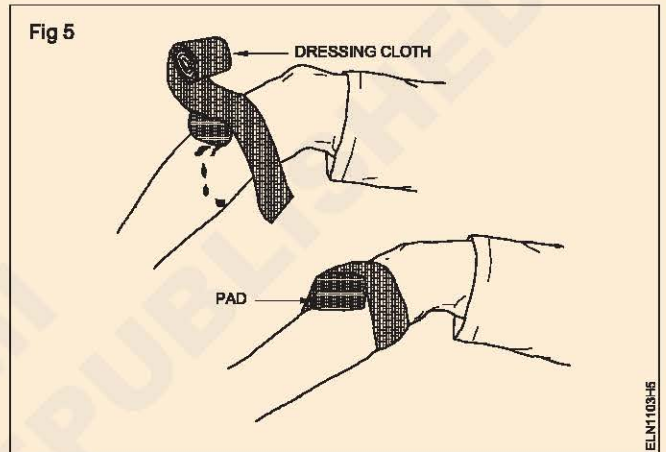

Practice safe methods of fire fighting in case of electrical fire

Scan the QR Code to view the video for this exercise

Objectives: At the end of this exercise you shall be able to

- **demonstrate the ability of fire-fighting during electrical fire**
- **as a member of the fire-fighting team**
- **as a leader of the group.**

Requirements
Equipment/Machines
<ul style="list-style-type: none"> ▪ Fire extinguishers-CO₂ - 1 No.

PROCEDURE**General procedure to be adopted during electrical fire**

1 Raise an alarm. Follow the methods given below to raise an alarm signals when the fire breaks out.

- Raise your voice and shout Fire! Fire! to draw attention.
- Run towards fire alarm/bell to activate
- Switch off the mains (if possible)

2 When you hear the alarm signal:

- Stop working
- Turn off all machinery and power
- Switch off fans/air circulators/exhaust fans. (it's good to switch off the sub-main)

3 If you are not involved in the fire fighting:

- Leave the place using the emergency exit.
- Evacuate the premises
- Assemble at a safe place along with others
- Check, if anyone has called the fire services
- Close the doors and windows, but do not lock or bolt

As a member of the fire-fighting team

4 If you are involved in fire fighting:

- Take instructions to extinguish fire in an organised way.

If taking instructions:

- Follow the instructions, and obey. Be safe and do not get trapped.
- Do not use your own ideas.

As a leader of the group

If you are giving instructions:

- Locate and use CO₂ fire extinguisher
- Seek for sufficient assistance and inform the fire brigade
- Locate locally available suitable means to put out the fire
- Judge the magnitude of the fire, Ensure that emergency exit paths are clear with no obstructions and then attempt to evacuate the place. (Remove explosive materials, substances that would easily catch fire.
- Put off the fire with assistance identifying people with assigned responsibility for each activity.

5 Report the measures taken to put out the fire, to the authorities concerned.

Detailed reports on the fire accidents, even if they are small accidents, shall help in identification of the causes of the fire. The identified causes shall help in taking preventive measures to avoid similar occurrences in the future



Use of fire extinguishers

Objectives: At the end of this exercise you shall be able to

- select fire extinguishers according to the type of the fire
- operate the fire extinguisher
- extinguish the fire.



Scan the QR Code to view the video for this exercise

Requirements

Equipment/Machines

- | | | | |
|--------------------------------------|--------|--------------|---------|
| ▪ Fire extinguishers-CO ₂ | -1 No. | ▪ Cell phone | - 1 No. |
| ▪ Scissors 100mm | -1 No. | | |

PROCEDURE

- 1 Alert people in the surrounding area by shouting fire, fire when you see fire (Fig 1a & b).
- 2 Inform fire service or arrange to inform them immediately (Fig 1c).
- 3 Open the emergency exit and ask the people inside the area to go away (Fig 1d).
- 4 Switch "OFF" all electrical supply.
- 5 Analyze to identify the type of fire.
- 6 Assume that is type D fire (electrical fire).

Do not allow people to go near the fire.

Fig 1

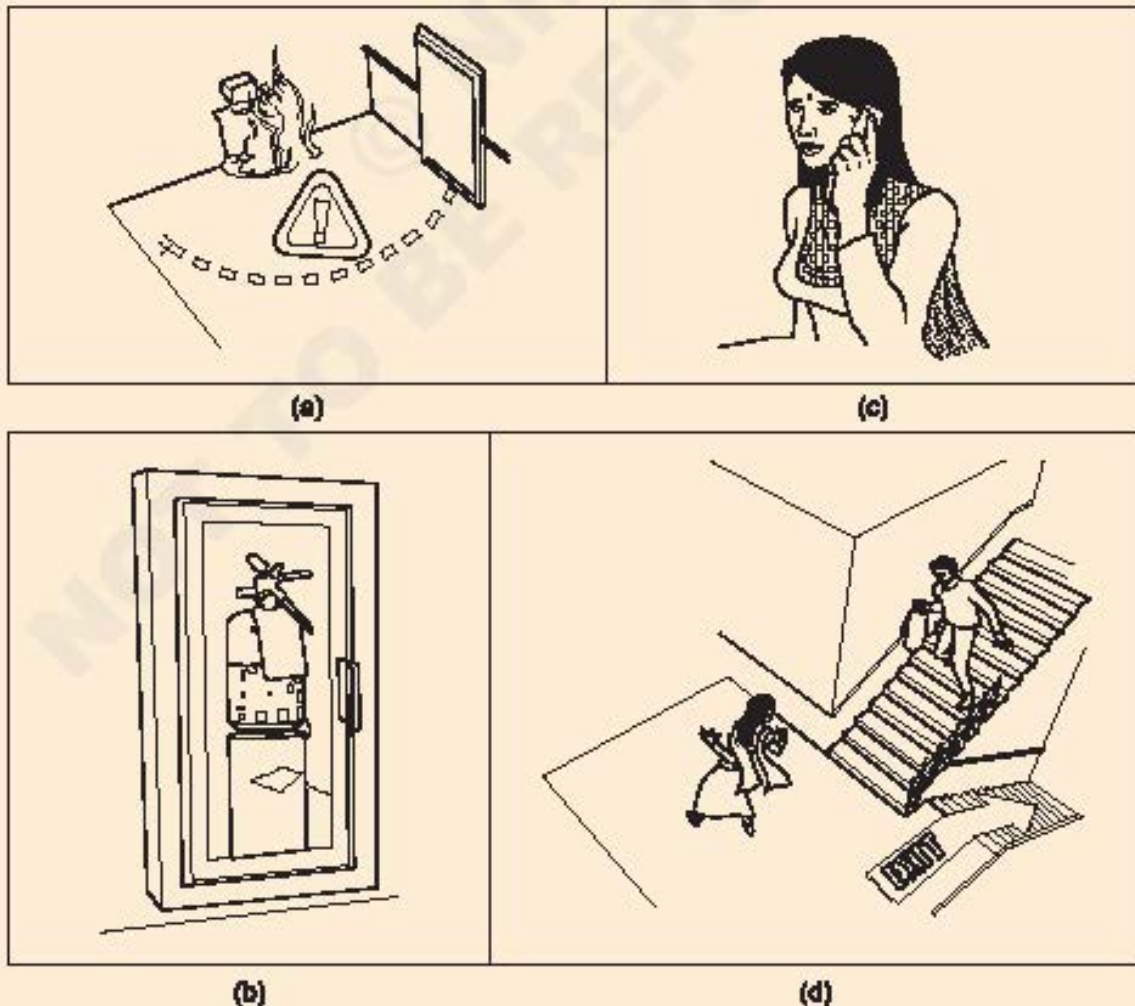

- 7 Select CO₂ (carbon dioxide) fire extinguisher.
- 8 Locate and take the CO₂ fire extinguisher. Check for its expiry date.
- 9 Break the seal. (Fig 2)

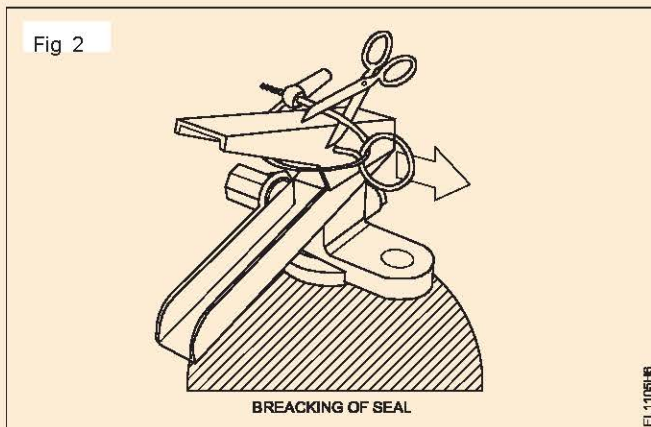

- 10 Pull the safety pin from the handle. (Fig 3) (the Pin is located at the top of the fire extinguisher.) (Fig 3)

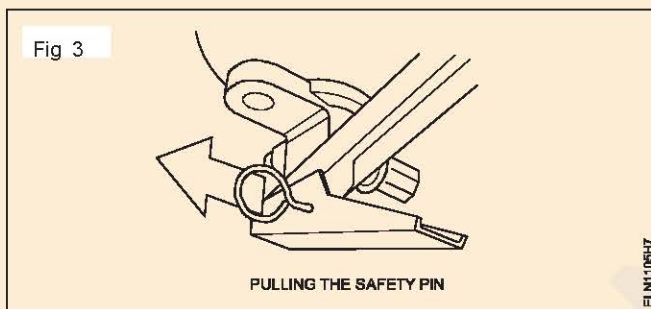

- 11 Aim the extinguisher nozzle or hose at the base of the fire. (This will remove the source of the fuel fire.) (Fig 4)

Keep your self low.

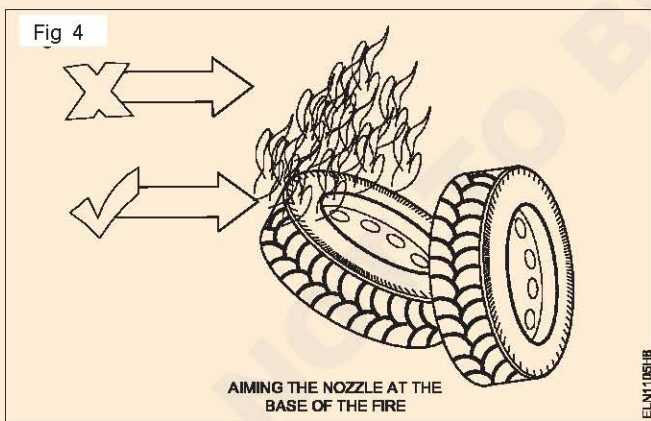

- 12 Slowly squeeze the handle lever to discharge the agent.
- 13 Sweep from side to side approximately 15 cm over the fuel fire until the fire is put off. (Fig 5)

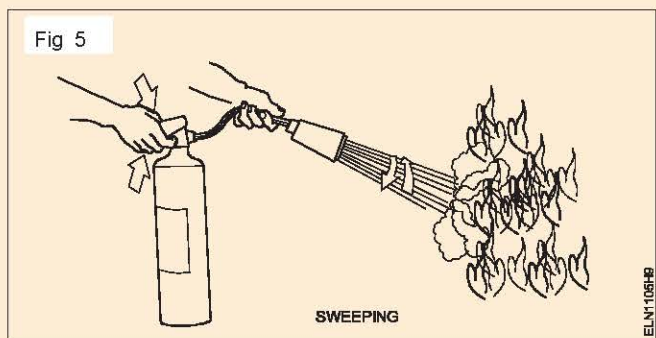

Fire extinguishers are manufactured for use from a distance.

Caution

- While putting off fire, the fire may flare up.
- Do not panic so long as it is being put off promptly
- If the fire does not respond well even after you have used the fire extinguisher, move away from the fire point.
- Do not attempt to put out a fire when it emits toxic smoke. Leave it to the professionals.
- Remember that your life is more important than the property. So do not take risks.

In order to remember the simple operation of fire extinguisher, remember P.A.S.S.

This will help to use the fire extinguisher.

- P** for pull
- A** for aim
- S** for squeeze
- S** for sweep



Scan the QR Code to view the video for this exercise

Practice elementary first aid

Objective : At the end of this exercise you shall be able to
• **prepare the victim for elementary first aid.**

Requirements

Equipment/Materials

- Number of Persons (Instructor can divide the trainees into suitable Number of groups.) - 20 Nos.

PROCEDURE

Assumption: For easy manageability, Instructor may divide the trainees into groups and ask each group to perform one method of resuscitation.

TASK 1: Prepare the victim before giving first-aid treatment

- 1 Loosen the tight clothing as it may interfere with the victim's breathing. (Fig 1)



- 2 Remove any foreign material or false teeth from the victim's mouth and keep the victim's mouth open. (Fig 2)
- 3 safely bring the victim to the level ground, taking the necessary safety measures. (Fig 3)

Do not waste too much time in loosening the clothes or trying to open the tightly closed mouth.

- 4 Avoid violent operations to prevent injury of the victim's internal parts.

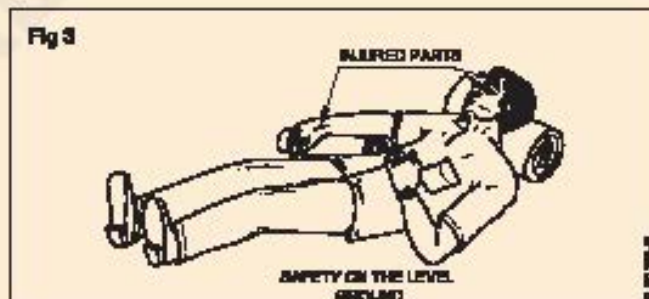

TASK 2: Prepare the victim for artificial respiration

If breathing has stopped, try to provide artificial respiration

- 1 Send word for professional assistance. (If no other person is available, you stay with the victim and help as best as you can.)
- 2 Look for visible injury in the body and decide on the suitable method of artificial respiration.
 - In the case of injury/burns on the chest and/or belly follow the mouth to mouth method.
 - In the case of burn and injury in the back, follow Nelson's method.

- 3 Place the victim in the correct position before giving artificial respiration.

**All actions should be taken immediately.
Delay by even a few seconds may be dangerous.**

- 4 Cover the victim with coat, sacks or improvise with your own method. Help to keep the victim's body warm.
- 5 Proceed to perform the suitable artificial respiration method.

Rescue a person and practice artificial respiration

Objective: At the end of this exercise you shall be able to

- rescue a victim from electric shock
- apply respiratory methods
 - Nelson's arm - Lift back method
 - Schafer's method
 - mouth to mouth method
 - mouth to nose method
 - revive breathing during cardiac arrest.



Scan the QR Code to view the video for this exercise

Requirements

Equipment/Materials

- | | | | |
|-----------------------------|---------|---------------------------------------|---------|
| ▪ Control panel arrangement | - 1 No. | ▪ Wooden stick | - 1 No. |
| ▪ Motor | - 1 No. | ▪ 2 persons for demonstration purpose | |
| ▪ Rubber mat | - 1 No. | | |

PROCEDURE

TASK 1: Rescue a person (mock victim) from live supply (simulated)

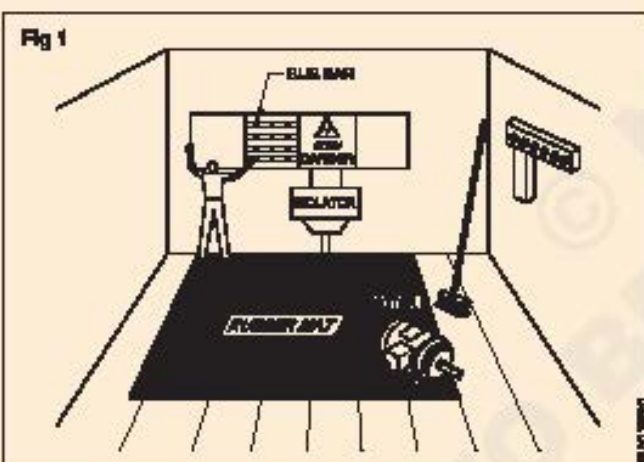

- 1 Observe the person (mock victim) receiving an electric shock. Interpret the situation quickly.

- 2 Safely move the victim away from the 'live' equipment by disconnecting the supply or using any insulating material. (Fig 1)

Do not run to switch off the supply that is far away.

Do not touch the victim with bare hands until the circuit is made dead or the victim is moved away from the equipment.

Push or pull the victim away from the point of contact of the live equipment, without causing serious injury to the victim.

- 3 Physically move the victim to a nearby place.
- 4 Take steps to revive breathing if the victim is unconscious and not breathing.

TASK 2: Revive breathing in the victim by Nelson's arm-Lift back pressure method

Nelson's arm-lift back pressure method must not be used when there are injuries to the chest and belly.

- 1 Place the victim with his arms folded with the palms one over the other and the head resting facing the ground with his cheek over the palms.
- 2 Kneel on one or both knees near the victim's head.
- 3 Place your hands on the victim's back beyond the line of the armpits, with your fingers spread outwards and downwards, thumbs just touching as in Fig 2.

- 4 Gently rock forward keeping your arms straight until they are nearly vertical, and steadily keep pressing the victim's back as shown in Fig 3 to force the air out of the victim's lungs.
- 5 Synchronise the above movement of rocking back with your hands sliding downwards along the victim's arms, and grasp his upper arm just above the elbows as shown in Fig 4. Continue to rock back wards.
- 6 As you rock back, gently raise and pull the victim's arms towards you as shown in Fig 5 until you feel the tension in his shoulders. To complete the cycle, lower the victim's arms and move your hands up to the initial position.

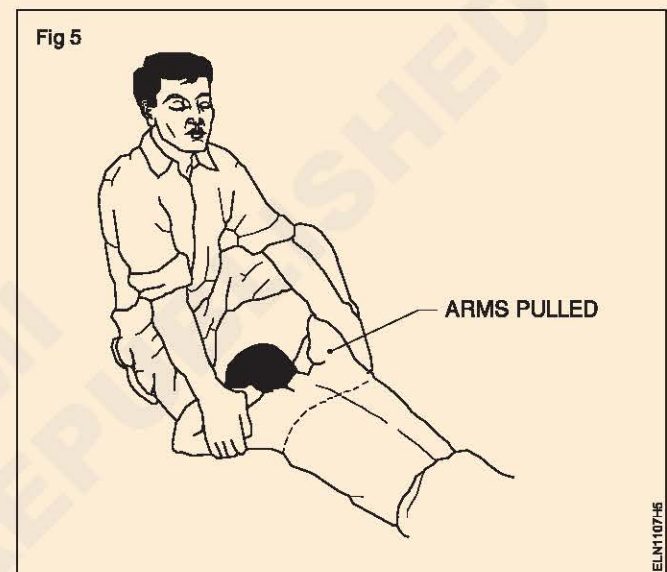
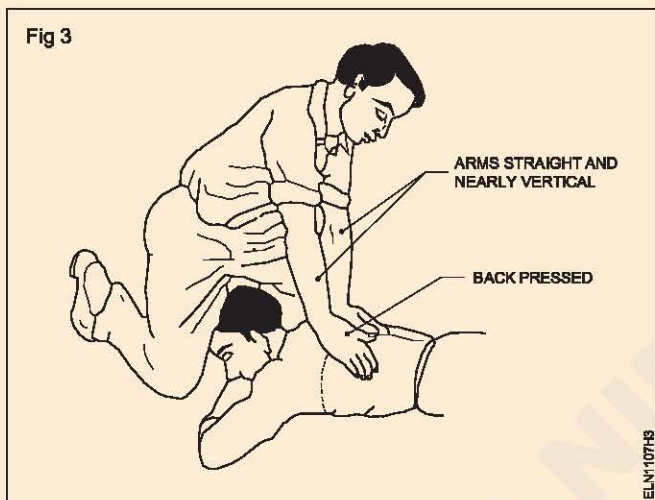
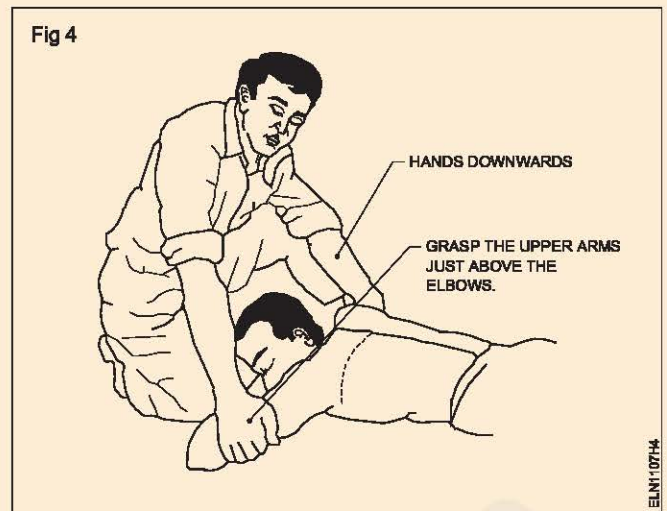
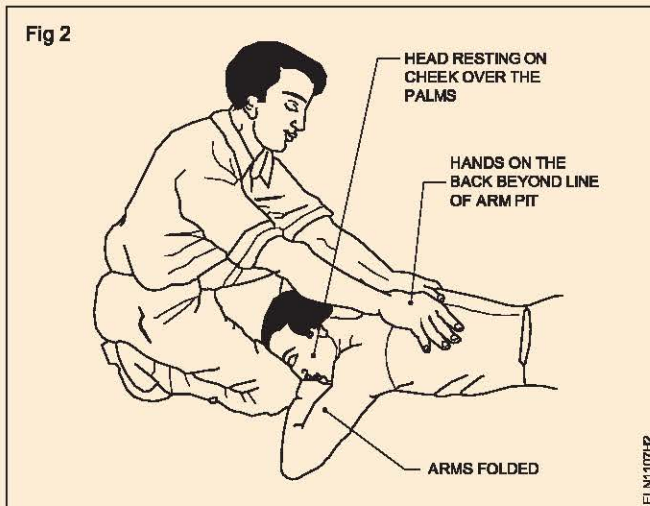

7 Continue artificial respiration till the victim starts to breathe naturally. Please note, in some cases, it may take hours.

8 When the victim revives, keep the victim warm with a blanket, wrapped around him or with hot water bottles or warm bricks. Stimulate blood circulation towards the heart by stroking the insides of the arms and legs.

9 Keep him in the lying position and do not let him exert himself.

Do not give him any stimulant, until he is fully conscious.

TASK 3 : Revive breathing in the victim by Schafer's method

Do not use this method when the victim has injuries on the chest and belly.

- 1 Lay the victim on his belly, one arm extended direct forward, the other arm bent at the elbow and with the face turned sideward and resting on the hand or forearm as shown in Fig 6.
- 2 Kneel when the victim is astride, so that his thighs are between your knees with your fingers and thumbs positioned as in Fig 6.
- 3 With the arms held straight, slowly swing forward so that the weight of your body is gradually brought to bear upon the lower ribs of the victim to force the air out of the victim's lungs as shown in Fig 7.
- 4 Now immediately swing backwards removing all the pressure from the victim's body as shown in Fig 8, to allow the lungs to fill with air.

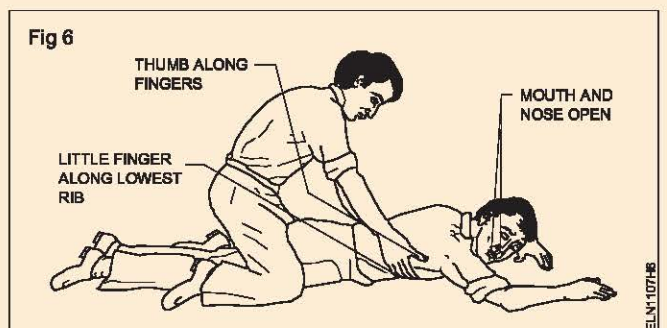

5 After two seconds, swing again forward and repeat the cycle twelve to fifteen times per minute.

6 Continue it till the victim begins to breathe naturally.

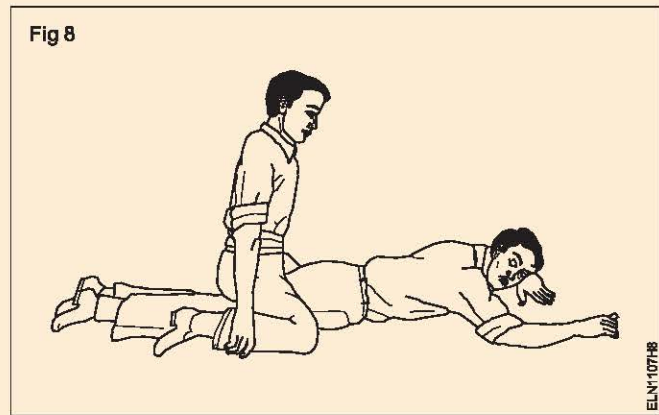
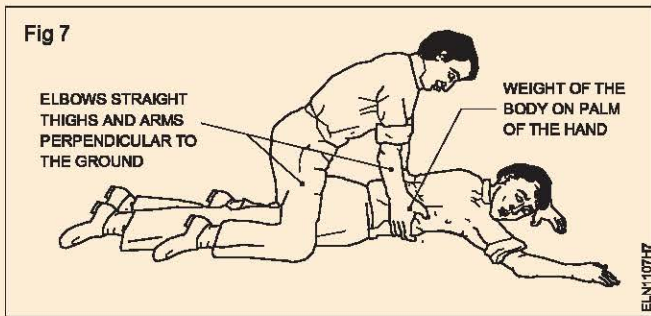

TASK 4: Revive breathing in the victim by mouth-to-mouth method

- 1 Lay the victim flat on his back and place a cloth roll under his shoulders to ensure that his head is thrown well back. (Fig 9)

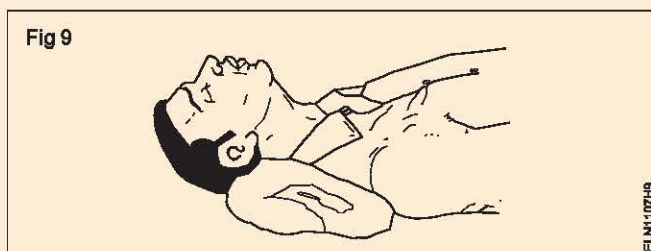

- 2 Tilt the victim's head back so that the chin points straight upwards. (Fig 10)

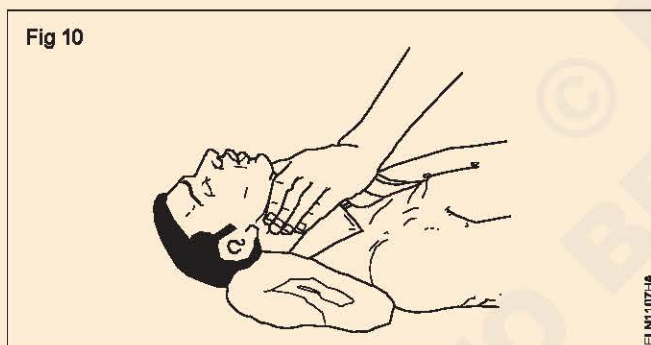

- 3 Grasp the victim's jaw as shown in Fig 11, and raise it upwards until the lower teeth are higher than the upper teeth you may also place your fingers on both sides of the jaw near the victim's ear lobes and pull upward. Maintain this jaw position throughout the duration to revive respiration to prevent the tongue from blocking the air passage.

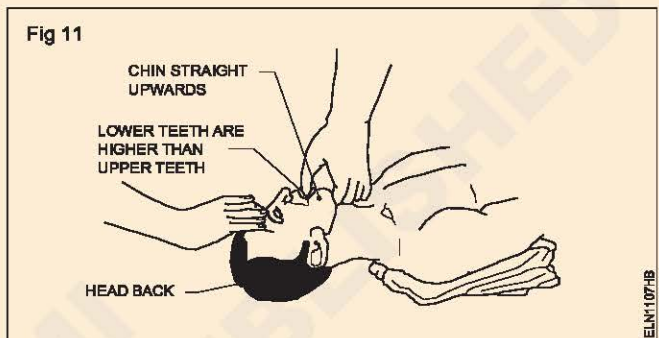

- 4 Take a deep breath and place your mouth over the victim's mouth as shown in Fig 12 making airtight contact. Pinch the victim's nose shut with the thumb and forefinger. If you dislike direct contact, place a porous cloth between your mouth and that of the victim's. For an infant, place your mouth over the infant's mouth and nose. (Fig 12)

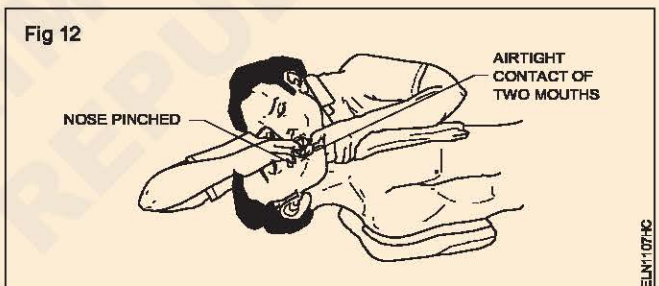

- 5 Blow into the victim's mouth (gently in the case of an infant) until his chest rises. Remove your mouth and release the hold on the nose, to let him exhale, turning your head to hear gushing the out of air. The first 8 to 10 breathings should be as rapid as the victim responds. Thereafter the rate should be slowed down to about 12 times per victim's minute (20 times for an infant).

If air cannot be blown in, check the position of the victim's head and jaw and recheck the mouth for obstructions. Then, try again more forcefully. If the chest still does not rise, turn the victim's face down and strike his back sharply to dislodge obstructions.

Sometimes air enters the victim's stomach as evidenced is the swelling of the stomach. Expel the air by gently pressing the stomach during the exhalation period.

Disposal procedure of waste materials

Objectives: At the end of this exercise you shall be able to

- identify the different type of waste material
- segregate the waste materials in the respective bins
- sort non-saleable and saleable materials separately and maintain record.



Scan the QR Code to view the video for this exercise

Requirements**Materials**

- | | | | |
|----------------------|----------|-----------------------|-----------|
| ▪ Shovel | - 1 No. | ▪ Trolley with wheels | - 3 Nos. |
| ▪ Plastic/Metal bins | - 4 Nos. | ▪ Brush and gloves | - 1 P air |

PROCEDURE

- 1 Collect all the waste materials in the workshop.
- 2 Identify and segregate them like cotton waste, metal chips, chemical waste and electrical waste (Fig 1) separately and label them.
- 3 Sort waste materials as saleable, non saleable, organic and inorganic materials.
- 4 Record the sorted waste material and fill Table-1.

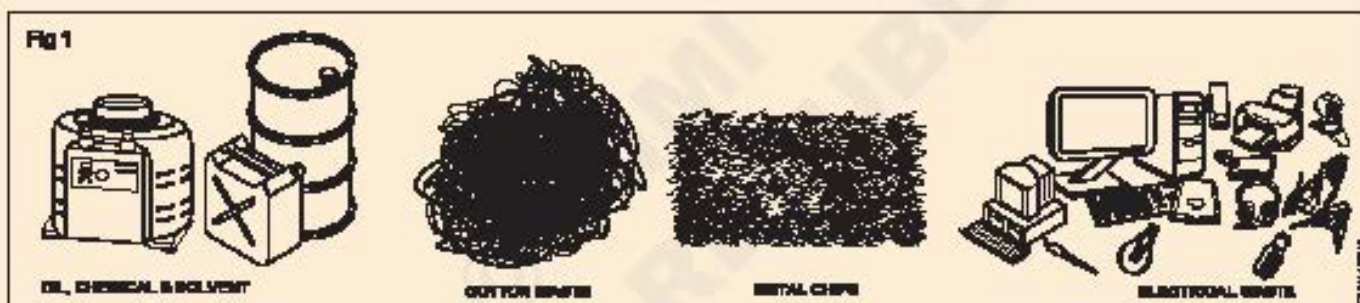
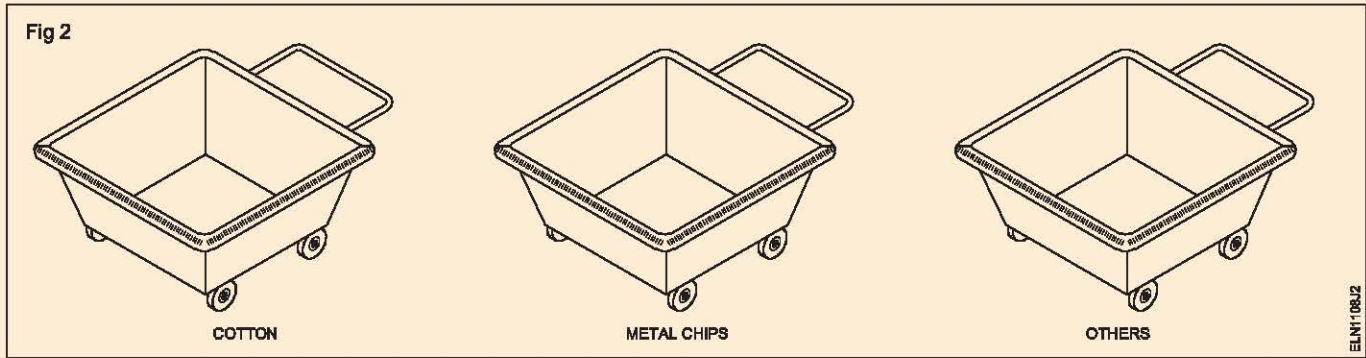

Table-1

Sl.No.	Name of the waste material	Quantity	Saleable or non Saleable
1			
2			
3			
4			
5			
6			

- 5 Arrange at least 3 trolleys with wheels for disposal. Stick label on each trolley as "Cotton Waste", "Metal Chips" and "others". (Fig 2)
- 6 Put the cotton waste in the cotton trolley and similarly put the metal chips waste and others in the respective trolleys.



7 Keep 4 more bins to collect saleable scrap, non saleable scrap, organic waste and Inorganic waste and label them. (Fig 3)



Skill Sequence

Separate the cotton waste and dispose it

Objectives: This shall help you to

- separate and dispose cotton waste.

- 1 Collect the chips by hand shovel with the help of a brush.
- 2 Clean the floor if oil has been spilt.

**Do not handle the chip with bare hand.
Separate the chip according to the metal.**

- 3 Separate the cotton waste and store it in the bin provided for the purpose.
- 4 Store the each category in the assigned bins.

Each bin has respective label.

- 5 Collect all the saleable material and non saleable one separately and put them in the respective bins.
- 6 Collect all the non-saleable materials like cotton waste, paper waste, wooden pieces, etc., and keep them in the respective bin as in Fig 3.
- 7 Check the non-saleable material (organic) and send it for disposal by burning after getting approval.
- 8 Check the saleable material and segregate like Aluminium, Copper, Iron, Screws, nuts and other items separately and send it to the stores for disposal by auction (or) as per recommended procedure.

Use of personal protective equipment

Objectives: At the end of this exercise you shall be able to

- read and interpret different types of Personal Protective Equipment (PPE) from the chart (or) real PPE
- identify and name the PPEs corresponding to the type of protection and write their uses.

Requirements

Tools / Equipment



- Chart showing different types of PPEs - 1 No.
- Real PPEs(available in section) - as required.

PROCEDURE

Instructor may arrange the available different types of PPEs in the table or provide the chart showing the PPEs. Instructor may also explain the types of PPEs and their uses, and the hazards for which each type is used.

- 1 Identify the different types of PPEs and write their names with the help of the chart and write in Table 1.
- 2 Write the type of protection and uses in the space provided against each PPE in Table 1.

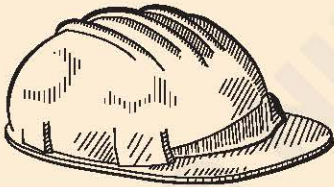
Table 1

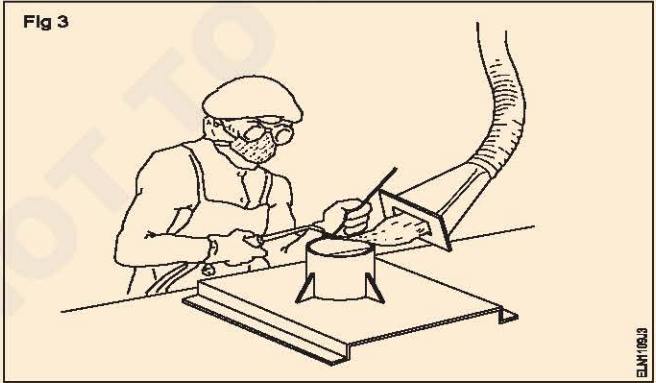
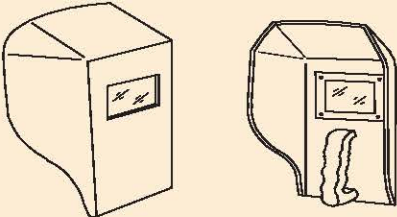
Sl. No.	Sketches	Name of PPE	Type of protection	Uses
1	<p>Fig 1</p> 			
2	<p>Fig 2</p> 			
3	<p>Fig 3</p> 			
4	<p>Fig 4</p> 			

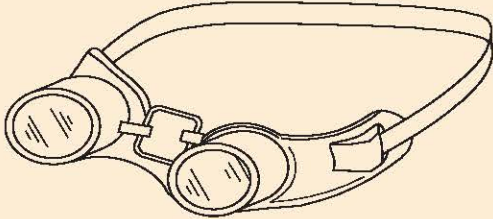
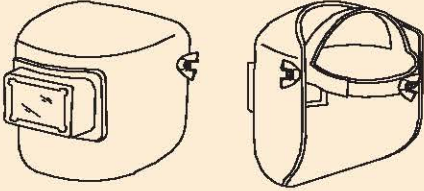
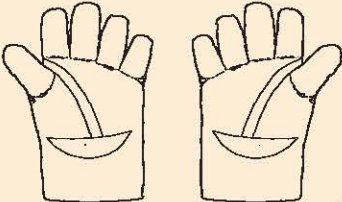
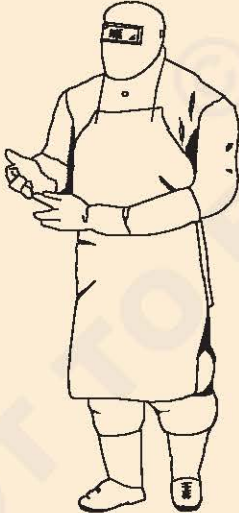
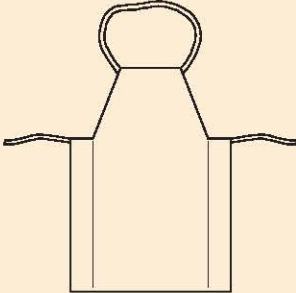
Sl. No.	Sketches	Name of PPE	Type of protection	Uses
5	<p>Fig 5</p>  <p>ELM1108A5</p>			
6	<p>Fig 6</p>  <p>ELM1108A6</p>			
7	<p>Fig 7</p>  <p>ELM1108A7</p>			
8	<p>Fig 8</p>  <p>ELM1108A8</p>			
9	<p>Fig 9</p>  <p>ELM1108A9</p>			

3 Get it checked by your instructor.

Practice on cleanliness and procedure to maintain it



Scan the QR Code to view the video for this exercise

Objectives: At the end of this exercise you shall be able to

- identify the places/machinery/equipment that are to be cleaned
- collect the cleaning materials/devices required for cleaning
- clean the machines/equipment and devices installed in your section.

Requirements			
Tools / Equipment		Materials	
▪ Portable vacuum cleaner/blower	- 1 No.	▪ Emery sheet-'O' grade	- 1 No.
		▪ Dusting cloth	- as required.
		▪ Dust bin	- 3 Nos. (labelled)

PROCEDURE

Switch OFF all the machinery and equipment before starting the cleaning process. Use a mask or cover the mouth and nose.

Instructor has to brief the Japanese 5S concept to the trainees before starting the work.

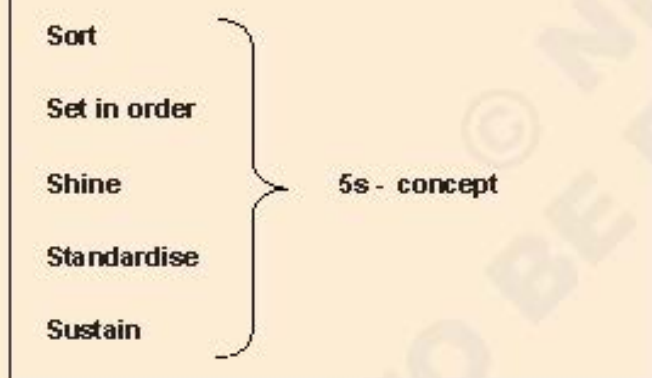

- 1 Identify the areas/equipment/machine that need to be cleaned.
- 2 Keep the movable items in one place and group them.
- 3 Clean the dust carefully, without damaging any part/ connection in the machine / equipment, using a cloth.
- 4 Use wet dusting cloth on areas that are wired.
- 5 Remove rust on parts of the equipment (or) devices using an emery sheet.

Do not remove lubricants in the machine while wiping/cleaning.

- 6 Use vacuum cleaner to suck dust from areas where a brush or cloth cannot help.
- 7 Collect the waste materials found in the lab and put it in the specified dustbin, as shown in Fig 1.

Dusting and cleaning can be arranged by dividing the trainees into groups under the supervision of the instructor.

- 8 Clean places where water or oil has been spilt on the floor

Note down abnormal things that you noticed while cleaning and report it to the instructor to take corrective action.

- 9 Put all the materials and equipment used for cleaning in their respective places.
- 10 Inspect and ensure that all machines are working after cleaning in the presence of the instructor.
- 11 Discuss abnormal things that you came across while cleaning with the instructor. Prepare a report if the instructor asks for it

Instructor may assign trainees the responsibility of cleaning in batches. Disposal of waste may be organised as a routine activity by coordinating with the stores.



Identify trade tools and machineries

Objectives : At the end of this exercise you shall be able to

- **identify tools and draw their sketches**
- **identify the machineries in the lab and note down their names.**

Requirements			
Tools/Instruments		Equipment/Machines	
• Combination plier (150 mm)	- 1 No.	• Electric bench grinder	- 1 No.
• Long nose plier (200 mm)	- 1 No.	Materials	
• Screwdriver (150 mm)	- 1 No.	• Lubricating oil	- 100 ml
• Firmer chisel (12 mm)	- 1 No.	• Cotton waste	- as required.
• Ball pein hammer 125gm	- 1 No.	• Cotton cloth	- 0.50 m
• Flat file bastard (250 mm)	- 1 No.	• Grease	- as required.
• Flat cold chisel 15mm X 150mm	- 1 No.	• Emery sheet	- 1 sheet.
• Gimlet (4 mm x 150 mm)	- 1 No.		
• Centre punch	- 1 No.		
• Rawl jumper holder with bit No. 8	- 1 No.		

The instructor shall arrange for the necessary tool/equipment from other sections and also arrange for the required materials from scrap for practising the use of tools.

PROCEDURE

TASK 1 : Identify tools with specification

Assumption - A set of trainees tool kit and specified tools as given in this exercise are displayed on the workbench. Trainees are required to identify the tools from the specifications given and draw the sketch of the tools in the space allotted for the purpose.

- 1 Identify the tools from the specification given.
- 2 Draw a neat sketch against each item.

In case the specifications are different write the correct specification of the items given to you.

- 3 Get your sketches checked by your instructor.

Table 1

Sl. No.	Name of tool with specification	Sketch of tools
i	Combination plier with pipe grip, side cutter and insulated handle - size 150 mm,	
ii	Long nose pliers 200 mm,	
iii	Screwdriver 150 mm	
iv	Firmer chisel 12 mm	
v	Ball pein hammer 125 gms	
vi	Flat file bastard 250 mm	
vii	Flat cold chisel 15mm X 150mm	
viii	Gimlet 4 mm x 150 mm	
ix	Centre punch	
x	Rawl jumper holder with bit No.8	

TASK 2: Identify the machineries installed in the electrician section

Instructor shall explain the names of the machineries installed in the electrician section and their locations. Then ask the trainees to write the name, and other details of each machine in the section.

- 1 Write the name and other details of each machine against their names in Table 2.
- 2 Get it checked by your instructor.

Table-2

SI. No.	Name of the machine	Name and other details
1	Motor Generator set (A.C. motor with D.C generator)	
2	D.C. Series motor	
3	D.C. Shunt motor	
4	D.C. Compound motor	
5	Motor generator set (D.C. motor with A.C generator)	
6	A.C. Squirrel cage induction motor	
7	A.C Slip ring induction motor	
8	Universal motor	
9	Synchronous motor	
10	Diesel generator set	

Practice safe methods of lifting and handling of tools and equipment

Objectives: At the end of this exercise you shall be able to

- demonstrate how to lift and handle heavy equipment during working conditions while
- lifting from floor
- during lift
- carrying
- lowering to bench
- lifting from bench
- lowering to floor.



Scan the QR Code to view the video for this exercise

Requirements

Tools and equipment

- Single phase one HP 240V/50Hz capacitor start induction motor - 1 No.
- D.E. Spanner set 5 mm to 20 mm - set of 8 - 1 No.
- Work bench or table - 1 No.

PROCEDURE

Instructor has to demonstrate, how to lift and handle heavy equipment and then ask the trainees to practice.

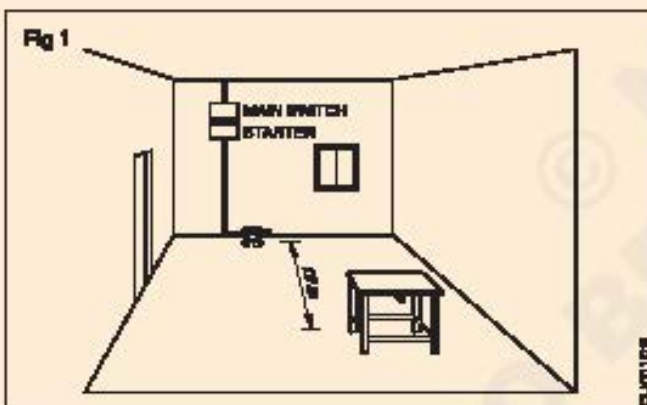

Assume one single phase motor has to be lifted and lowered to be placed on the floor. (Fig 1)

- 1 Switch OFF the motor and remove the fuse carriers.

Ensure that the equipment is disconnected from power supply and that the base plate nuts of the motor have been removed.

- 2 Ensure that you know the position where the equipment is to be placed.
- 3 Assess whether you need any assistance to carry the equipment.

- 4 Check for clear route to the location where the motor is to be placed. Remove obstacles, if any.
- 5 Position yourself close to the equipment to be lifted.
- 6 Lift the equipment from the floor using the correct posture.
- 7 Carry the equipment to the work bench safely, keeping the equipment close to your body.
- 8 place the equipment carefully on the bench, and adjust it to the correct position.

Assume that the overhauling work is over and the motor is to be placed in its original place.

- 9 Lift the equipment correctly with a firm grip.
- 10 Carry the equipment to its original place.
- 11 Safely lower the equipment with your feet apart, knees bent, back straight and arms close to your body.
- 12 Safely place the equipment on the floor.

If you feel the equipment is too heavy, take help from others.



Scan the QR Code to view the video for this exercise

Select proper tools for operation and precautions in operation



Scan the QR Code to view the video for this exercise

Objectives : At the end of this exercise you shall be able to

- select proper tools for specific uses.
- follow care and maintenance and procedures with precaution for each tool.

Requirements			
Tools			
▪ Combination plier - 150 mm	- 1 No.	▪ Firmer chisel 12 mm	- 1 No.
▪ Flat nose plier 150 mm	- 1 No.	▪ Tenon saw 300 mm	- 1 No.
▪ Diagonal cutting plier 150 mm	- 1 No.	▪ Plumb bob	- 1 No.
▪ Round nose plier 150 mm	- 1 No.	▪ Centre punch 50 mm	- 1 No.
▪ Screwdriver 150 mm	- 1 No.	▪ Cold chisel	- 1 No.
▪ Star-headed screwdriver 100 mm	- 1 No.	▪ Hack saw frame with blade	- 1 No.
▪ Neon tester	- 1 No.	▪ Portable electric drilling machine	- 1 No.
▪ Electrician's knife 100 mm	- 1 No.		
▪ Try square 150 mm	- 1 No.		

PROCEDURE

TASK 1: Select the proper tools for specific uses

- 1 Identify proper tools for specific uses from Fig 1 to 16 ,
- 2 Write the uses of each selected tool and the precautions to be followed while handling in Table 1 .

Table 1

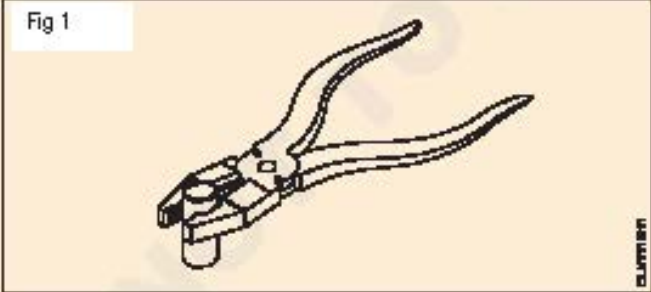
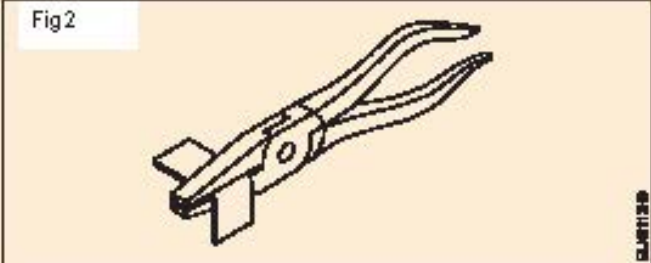
Tool	Uses/Operation/used for	Care, Maintenance and Precautions in operation
1 Combination pliers (Fig 1) 		
2 Pliers - flat nose 		

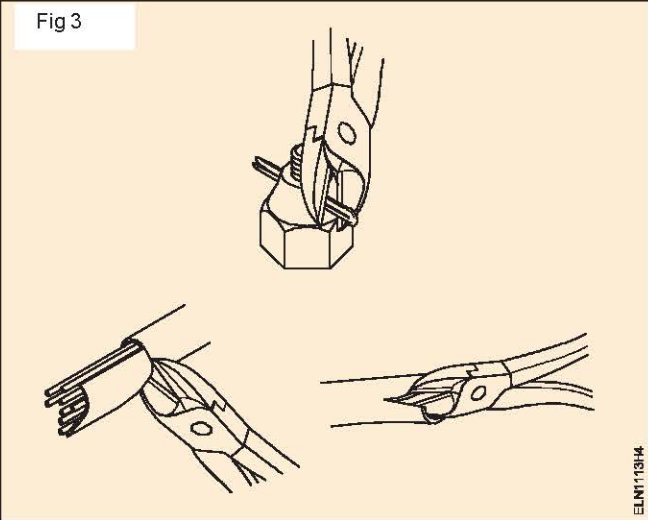
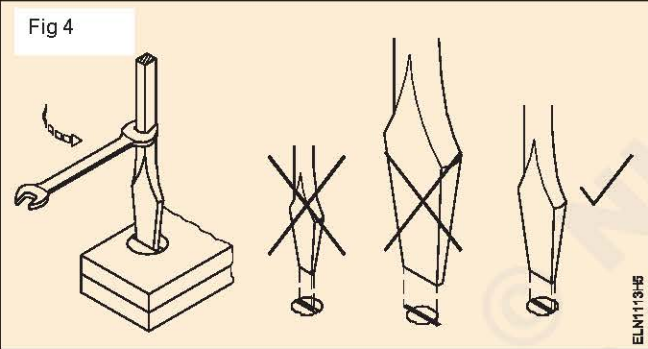
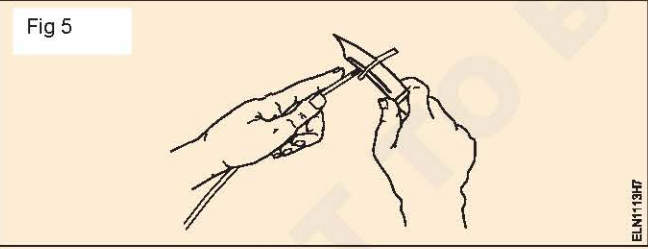
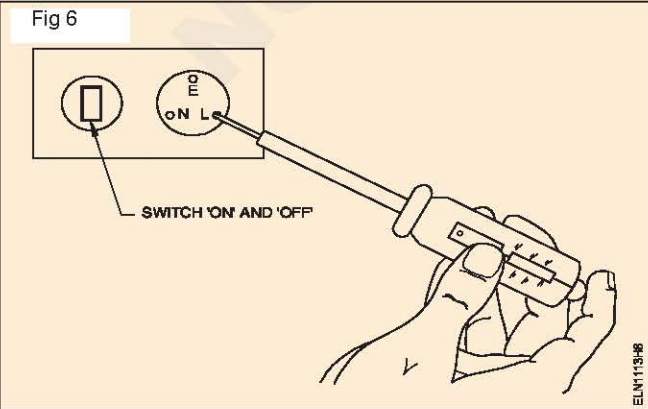
Tool	Uses/Operation used for	Care, Maintenance and Precautions in operation
<p>3 Pliers - diagonal cutting</p>  <p>Fig 3</p> <p>ELN113H4</p>		
<p>4 Screwdriver</p>  <p>Fig 4</p> <p>ELN113H5</p>		
<p>5 Electrician's knife</p>  <p>Fig 5</p> <p>ELN113H7</p>		
<p>6 Neon tester</p>  <p>Fig 6</p> <p>SWITCH 'ON' AND 'OFF'</p> <p>ELN113H8</p>		

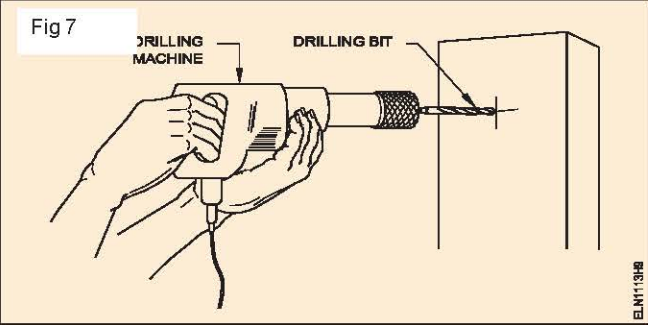
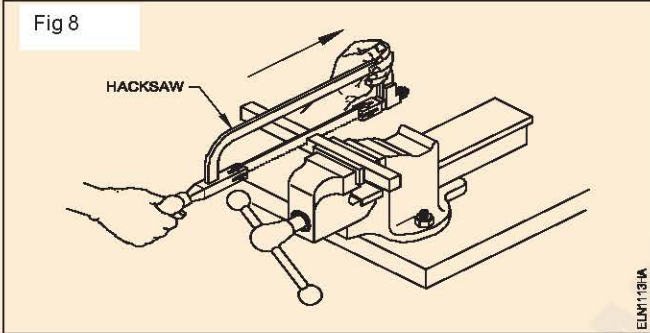
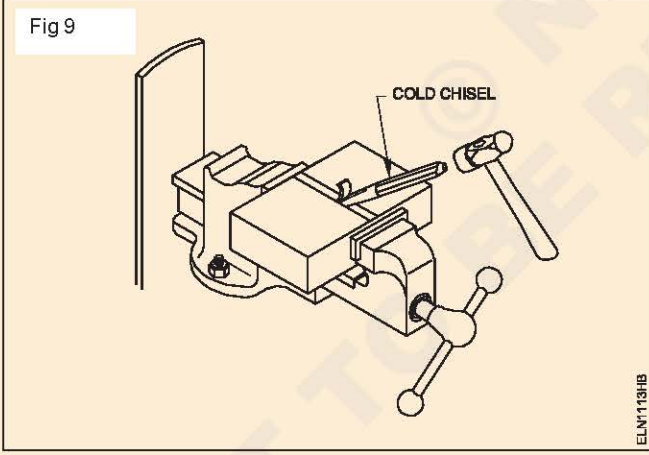
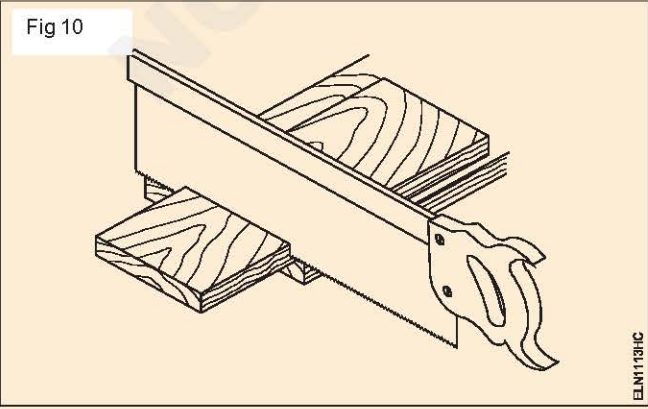
Tool	Uses/Operation used for	Care, Maintenance and Precautions in operation
<p>7 Portable electric drilling machine</p> 		
<p>8 Hacksaw</p> 		
<p>9 Cold chisel</p> 		
<p>10 Tenon saw</p> 		

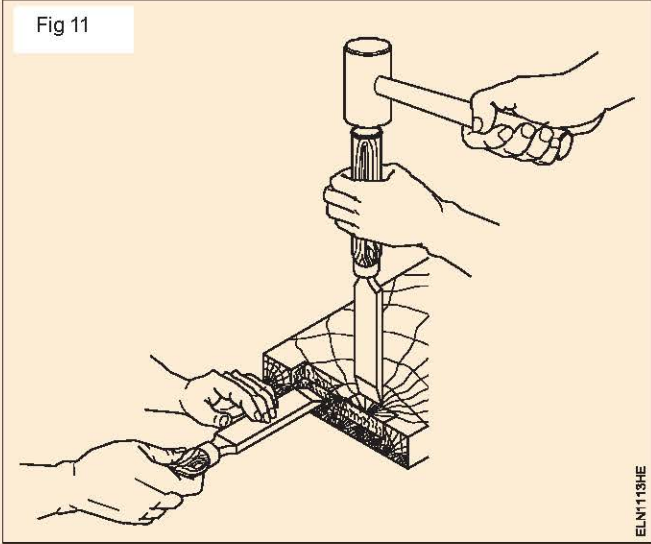
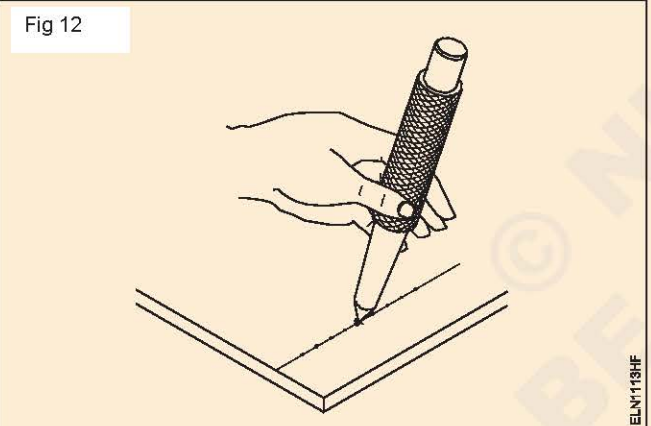
Tool	Uses/Operation	Care, Maintenance and
<p>11 Firmer chisel</p> <div data-bbox="113 304 767 846"> <p>Fig 11</p>  <p>ELN113HE</p> </div>		
<p>12 Centre punch</p> <div data-bbox="113 936 767 1361"> <p>Fig 12</p>  <p>ELN118HF</p> </div> <p>4 Get it checked by your instructor.</p>		

Care and maintenance of trade tools

Objective : At the end of this exercise you shall be able to
 • **perform care and maintenance of tools.**

Requirements	
<p>Tools/Instruments</p> <ul style="list-style-type: none"> • Combination plier (150 mm) - 1 Set. • Long round nose plier (200 mm) - 1 No. • Screwdriver (150 mm) - 1 No. • Firmer chisel (12 mm) - 1 No. • Wood rasp file (250 mm) - 1 No. • Flat file bastard (250 mm) - 1 No. • Bradawl (6mm x 150 mm) - 1 No. • Gimlet (4 mm x 150 mm) - 1 No. • Ratchet brace (6 mm) - 1 No. • Rawl jumper holder with bit No. 8 - 1 No. • Triangular file bastard (150mm) - 1 No. • Saw tooth setter - 1 No. 	<p>Equipment/Machines</p> <ul style="list-style-type: none"> • Electric bench grinder - 1 No. <p>Materials</p> <ul style="list-style-type: none"> • Lubricating oil - 100 ml • Cotton waste - as reqd. • Cotton cloth - 0.50 m • Grease - as reqd. • Emery sheet '00' - 1 sheet.

PROCEDURE

TASK 1: Perform care and maintenance of tools

Prevent rust formation

- 1 Inspect all the tools. If the tools are rusted, use fine emery paper to remove the rust.

While removing rust keep your hands safe from sharp edges. Do not use emery paper on steel rule or tape.

- 2 Apply a thin coat of oil over the surface of the rusted tool and clean with a cotton cloth.

A hammer should not have any trace of oil on its striking surface.

- 3 Check and lubricate tools for easy movement of the jaws of the pliers, blades of knives, jaws of wrench, pincers, gears of the hand drilling machine.
- 4 Apply a drop of oil on the hinged/geared surface, if the movement is hard.
- 5 Activate the jaws and gears till the muck/grim in the surfaces are cleaned
- 6 Apply a drop of oil again and clean the tools with a cotton cloth.

Remove the mushroom

- 7 Check the cold chisel and the hammer's striking face for mushrooms. If you find mushrooms report to your instructor to enable him to remove the mushroom through grinding.

Reshaping the screwdriver tip

- 8 Check the tips of the flat tipped screwdrivers. If the tip is blunt or disfigured report to the instructor.

Observe how the screwdriver tip is ground to form a perfect cornered tip for effective use.

Sharpen and set the saw-teeth

- 9 Check the teeth of the Tenon saw.
- 10 If the saw-teeth are blunt, report to your instructor.

Observe how the saw-teeth is filed to make the saw-teeth sharp.

- 11 Check the saw-teeth setting.

The teeth of the Tenon saw should be set to be able to alternately remove dust while sawing.

- 12 If the setting is not proper report to the instructor.
- 13 Check how the teeth are set by a saw-setter.

Operations of allied trade tools

Objectives : At the end of this exercise you shall be able to

- identify fitting, carpenter and sheetmetal tools
- write the names, specifications and operations of each tool.

Requirements
Tools
• Fitter, carpenter and sheetmetal tools - 1 set.

PROCEDURE

Instructor may display the fitter, carpenter and sheetmetal tools (allied trade) on the workbench in the section and demonstrate how to identify the tools, their operation with specifications. Then ask the trainees to record it in Table 1.

TASK 1: Identify fitter, carpenter and sheetmetal tools and mention their operation/uses

- | | |
|---|--|
| <p>1 Identify fitter, carpenter and sheetmetal tools provided on the workbench and recognise them with their names.</p> <p>2 Write the name of the tool against the visual shown in Table 1 and mention the specifications.</p> | <p>3 Write the operations / uses of each trade tool.</p> <p>Fitter - Fig 1 to 9</p> <p>Carpenter - Fig 1 to 9</p> <p>Sheet metal Worker - Fig 1 to 4</p> |
|---|--|

Table 1

Fitter Tools

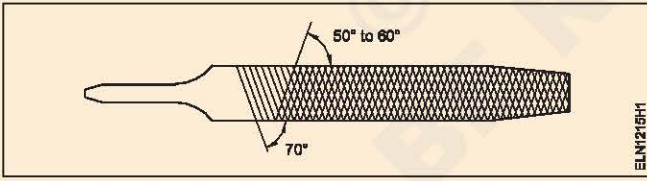
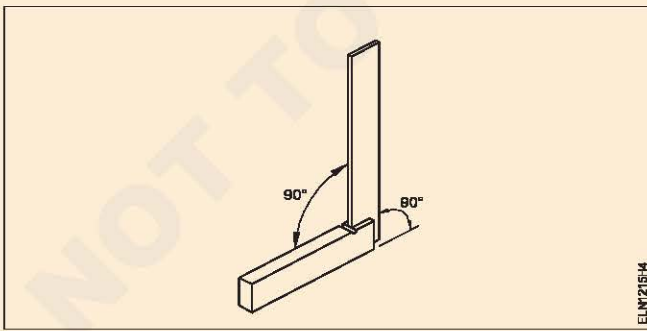
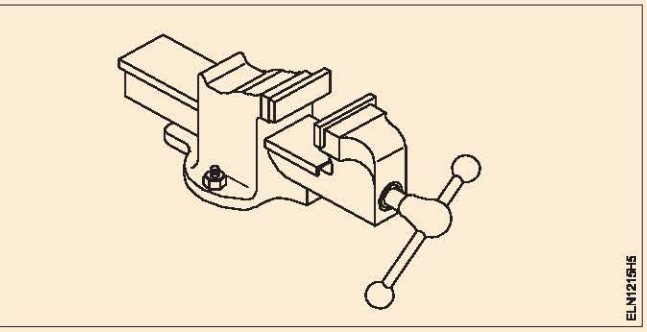
Sl. No.	Visual of tool	Name of the tool with specifications	Operation/ uses
1			
2			
3			



Sl. No.	Visual of tool	Name of the tool with specifications	Operation/ uses
4	 <p style="text-align: right; font-size: small;">ELN121516</p>		
5	 <p style="text-align: right; font-size: small;">ELN121517</p>		
6	 <p style="text-align: right; font-size: small;">ELN121518</p>		
7	 <p style="text-align: right; font-size: small;">ELN121519</p>		
8	 <p style="text-align: right; font-size: small;">ELN12151A</p>		
9	 <p style="text-align: right; font-size: small;">ELN12151B</p>		

Table 2
Carpentry tools

Sl. No.	Visual of tools	Name of the tool with specifications	Operation/ uses
1	 <p style="text-align: right; font-size: small;">ELN1215.1</p>		
2	 <p style="text-align: right; font-size: small;">ELN1215.3</p>		
3	 <p style="text-align: right; font-size: small;">ELN1215.4</p>		
4	 <p style="text-align: right; font-size: small;">ELN1215.5</p>		
5	 <p style="text-align: right; font-size: small;">ELN1215.6</p>		
6	 <p style="text-align: right; font-size: small;">ELN1215.7</p>		
7	 <p style="text-align: right; font-size: small;">ELN1215.8</p>		

Sl. No.	Visual of tool	Name of the tool with specifications	Operation/ uses
8	 ELN/2/15/8		
9	 ELN/2/15/9		

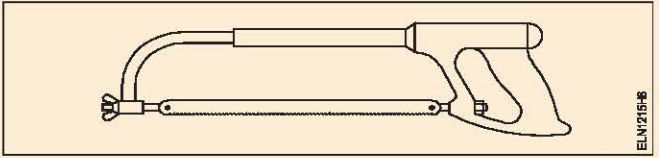
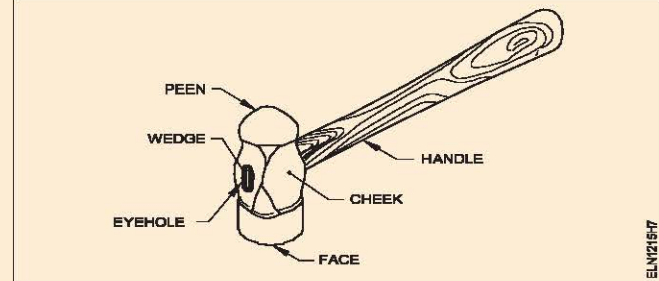
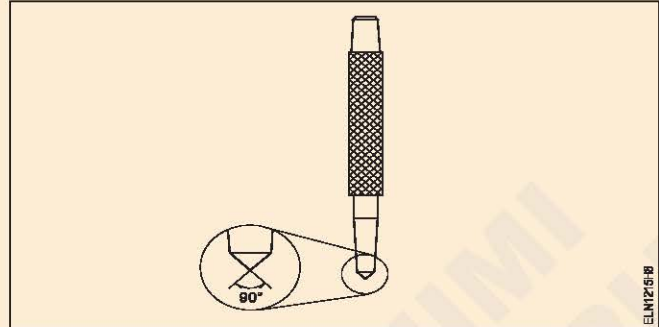
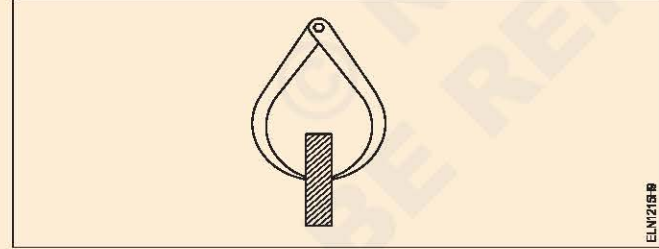
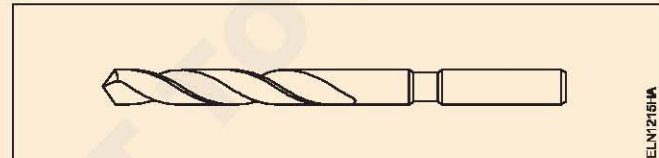
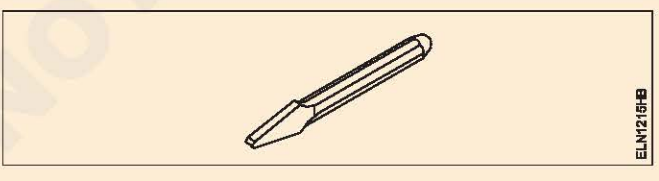
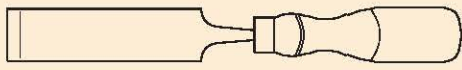
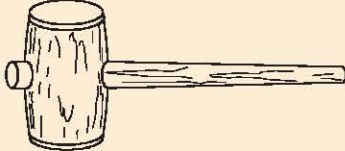
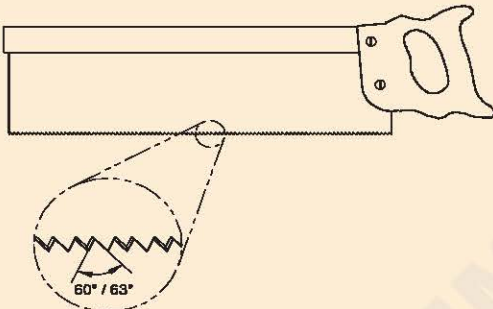
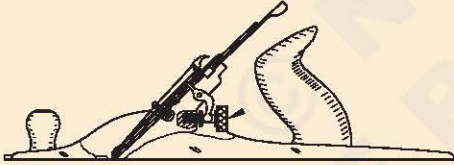
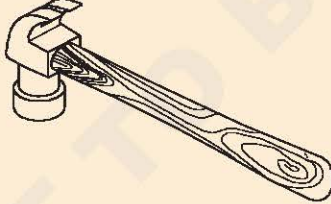
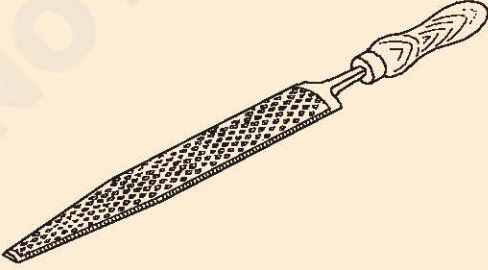
Table 3
Sheetmetal tools

Sl. No.	Visual of tools	Name of the tool with specifications	Operation/ uses
1	 ELN/2/15/1		
2	 ELN/2/15/2		
3	 ELN/2/15/3		
4	 ELN/2/15/4		

4 Get it checked by the instructor.

Workshop practice on filing and hacksawing

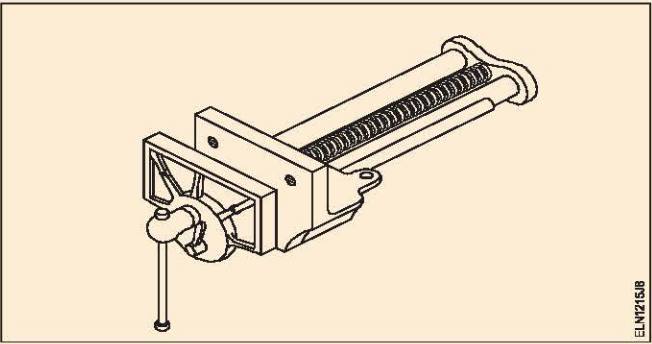
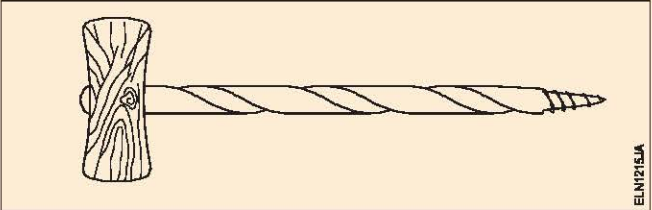
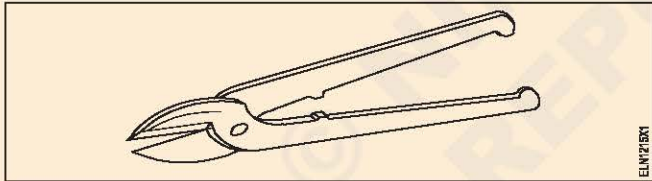
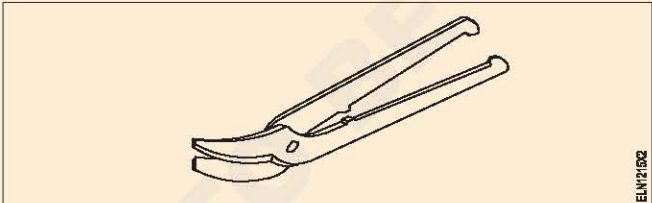
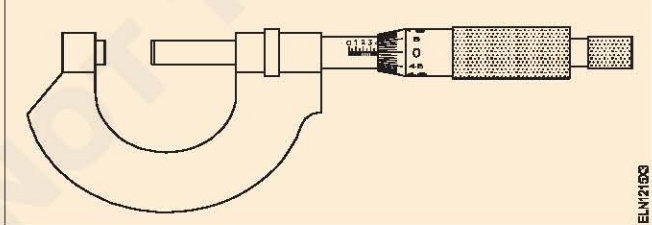
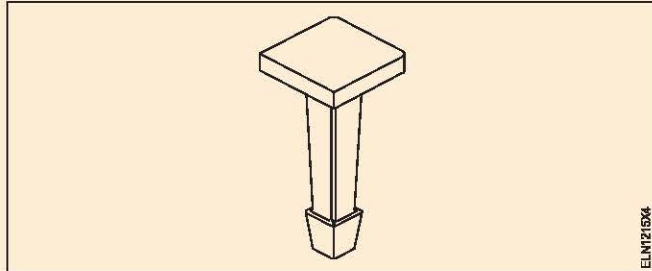
Objectives: At the end of this exercise you shall be able to

- file a surface flat and check it with straight edge and light gap
- file two adjacent sides to 90° and check it with Try square
- perform operations of marking a straight line
- file and finish surfaces to an accuracy of 0.5mm.



Scan the QR Code to view the video for this exercise

Requirements**Tools/Instruments**

- File, flat bastard, double cut - 300 mm - 1 No.
- File, flat second cut, double cut 300 mm - 1 No.
- Try square - 150 mm - 1 No.
- Jenny caliper - 150 mm - 1 No.
- Ball peen hammer - 200 gm - 1 No.
- Hack saw frame (200 mm) with blade (24 TPI) - 1 No.
- Mild steel square bar 25x25mmx50mm - 1 No.

Equipment/Machines

- Bench vice - 50 mm Jaw size - 1 No.

Materials

- ISA5555 Thickness - 8 mm
- Length - 150 mm.

PROCEDURE**TASK 1: Practice on filing**

- 1 Check the length and size of the given M.S. angle iron as per the sketch using a steel ruler.
- 2 Fix at right angle with one side (surface 'A') at least 15 mm above the jaws of the bench vice.
- 3 File the reference side (surface 'A' indicated in Fig 1) with the bastard file.
- 4 Test the flatness with the blade of the Try square.

**Do not touch the surface of the job while filing.
Use a vice clamp for protecting the finished surfaces.**

- 5 File the adjacent surface 'B' with a bastard file.
- 6 Test the flatness and also check the right angle with the Try square.
- 7 File the side 'C' at right angle to surfaces 'A', 'B'.
- 8 Evenly apply marking media (lump chalk) on the surfaces 'A' and 'B'.
- 9 Place surface 'B' on the levelling plate and scribe a line parallel to 'B' on surface 'A' at a distance of 53 mm as shown in Fig 1. Similarly on surface 'A' mark a line parallel to 'B' at a distance of 53 mm.
- 10 Place surface 'C' on the levelling plate and scribe a line parallel to 'C' on surfaces 'A' & 'B' at a distance of 146 mm from surface 'C'.
- 11 Punch all the scribed lines.
- 12 File the sides 'D', 'E' and 'F' with a bastard file.
- 13 Finish the job with a second cut file. File within ± 0.5 mm and check the right angles with reference to surfaces 'A' and 'B'.

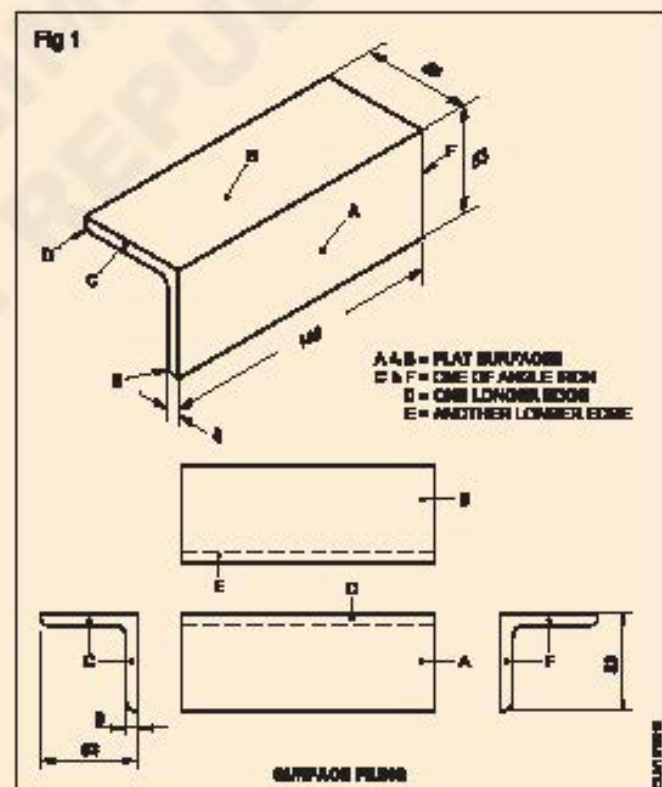

- 15 Deburr all sharp edges.

Do not overtighten the vice.

Do not allow any pining of the file handle. Use a file card for removing pining of the file.

Skill sequence

Types of filing

Objective: This shall help you to

- file a flat surface.

Filing method: The method of filing adopted depends on the type of surface profile to be filed, the type of surface texture required and the amount of materials to be removed.

Diagonal filing: This type of filing is done when heavy reduction of material is required. The strokes are at an angle of 45° . Because the stroke directions cross, the surface texture formed clearly indicates the high and low spots. Frequent checking of the level is not necessary, particularly, after one has developed a steady movement of the file. (Fig 1)

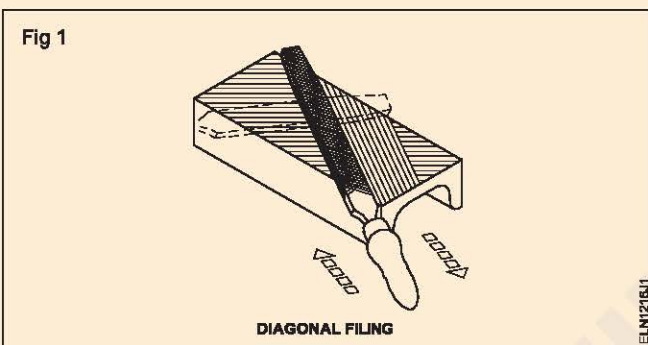

Transverse filing: In this method the file strokes are at right angles to the longer side of the work. This is commonly used to reduce material from the edges. Using this method, the size of the workpiece is brought close to the finishing size, and then final finishing is done by longitudinal filing. (Fig 2)

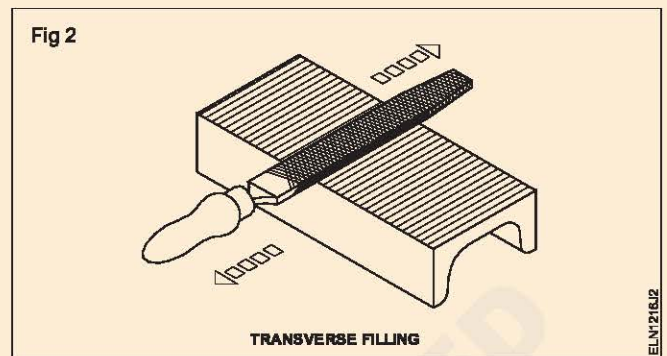

Longitudinal filing: The file is moved parallel to the longer side of the work. Usually all surfaces are smooth-finished by this method. The filed surface texture will show uniform and parallel lines. (Fig 3)

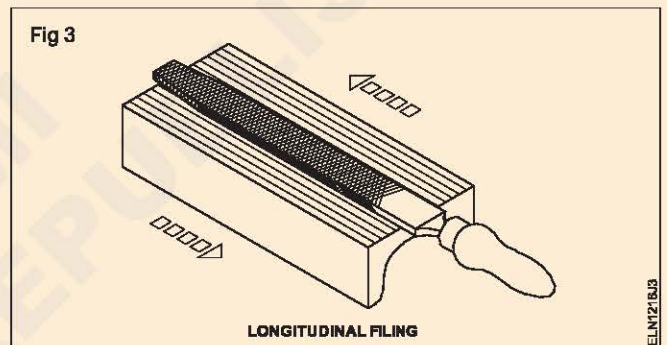

Method of using Centre Punch

Objectives: This shall help you to

- hold a centre punch over a scribed line
- punch by dot/centre punch.

Hold the punch in a relaxed manner between your thumb and your fingers. For centre/dot punching, place the workpiece on a steel support plate. Place the punch in position. Rest your hand on the workpiece while doing so. (Fig 1)

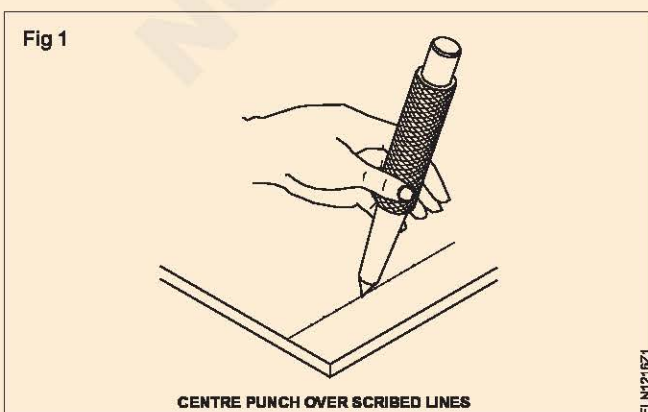

Place the point of the centre punch on the line of intersection. (Fig 2)

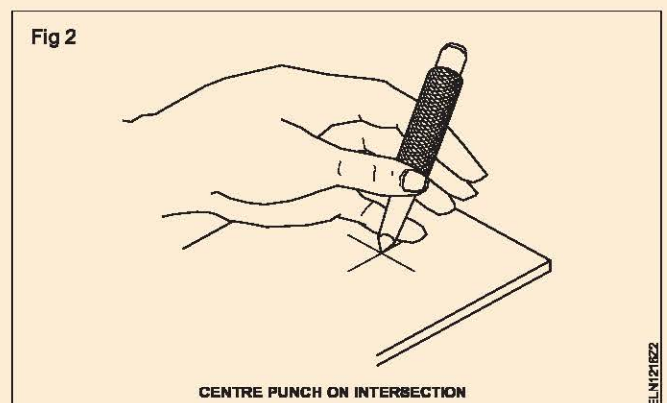

Bring the punch in perpendicular position to the surface of the workpiece. (Fig 3)

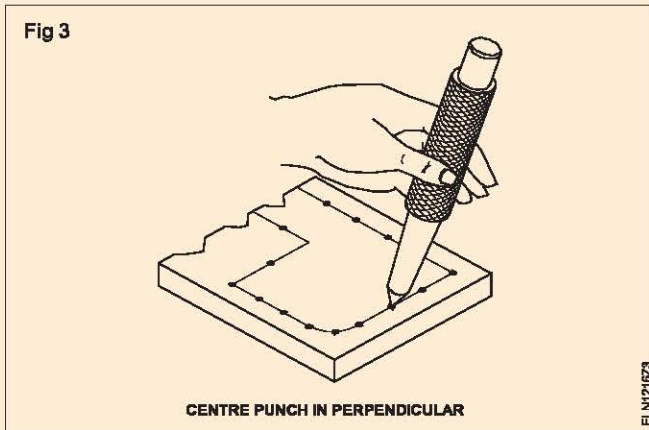

Tap the head of the punch with a light blow by a hammer. A heavier blow is required for marking the position of drilling a hole. (Fig 4)

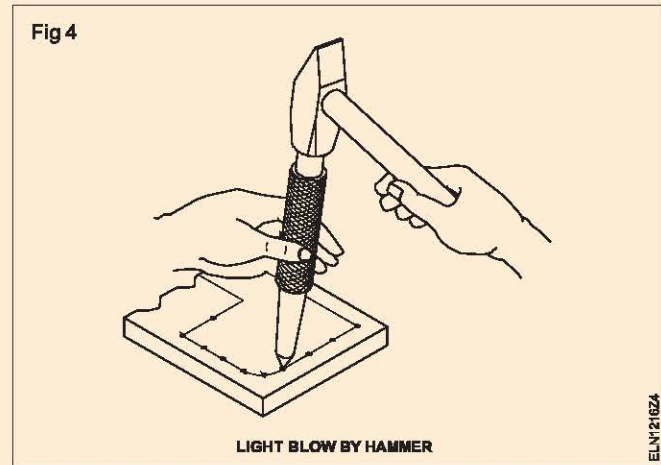

Sub Exercise (S. Ex.) 1.1.16 - 1

Practice in hacksawing

Objectives: At the end of this exercise you shall be able to

- file one face flat and check by straight edge and light gap
- file angle to 90° within Try square accuracy
- mark straight lines
- mark parallel lines using a surface gauge
- mark parallel lines using a Try square
- file and finish surfaces flat and parallel within $\pm 0.5\text{mm}$
- file and finish radius
- saw M.S.flat along a straight line.

Requirements

Tools/Instrumentss

- File, flat bastard, double cut 300 mm - 1 No.
- File, flat, second cut, double cut 300 mm - 1 No.
- Try square - engineer's rule 150 mm - 1 No.
- Jenny caliper 150 mm - 1 No.
- Engineer ball peen hammer 200 gm - 1 No.
- Centre punch 100 mm - 1 No.
- Dot punch - 1 No.
- Steel rule 300 mm - 1 No.
- Hacksaw blade 300 mm - 1 No.
- Surface gauge - 1 No.
- Radius gauge - 1 set.

- File card - 1 No.
- Vice clamp - 1 pair.
- Divider - 1 No.
- Straight edge - 1 No.

Equipment/Machines

- Bench vice 50 mm jaw - 1 No.
- Surface plate - 1 No.
- Angle plate - 1 No.

Materials

- 60 ISF 8 (Length - 350 mm.) - 2 Nos.

PROCEDURE

- 1 Check the raw material size with the sketch using the steel ruler.
- 2 Securely fix the job in the bench vice.
- 3 File the reference face A (Fig 1) with a bastard file.
- 4 Check the flatness with the straight edge.
- 5 File adjacent edge or datum edge B (Fig 1) with a bastard file.
- 6 Check the right angle with a Try square.
- 7 File adjacent edge or datum edge C (Fig 1) with a bastard file.
- 8 Check the right angles to the datum edge B and reference surface A.
- 9 Evenly apply chalk on the surface A.
- 10 Place the job on the levelling plate and scribe the lines by the surface gauge, parallel to the datum edge B (size 58 mm) and on datum edge C (size 350 mm).

- 11 Scribe the saw, cut parallel lines a, b, c & d as per the sketch. (Fig 1)
- 12 Scribe two arcs of radius 10 mm with the divider at the datum edge C as in the Fig 1.
- 13 Punch all the scribed lines and also the arcs by a dot punch.
- 14 File the edges D and E with a file.
- 15 Check for the right angle between edges D and E and also with the surface A.
- 16 Check the finished piece for length 350 mm and breadth 58 mm with an outside caliper.
- 17 Saw the depth a, b, c, and finally saw part at 'd' in Fig 1.
- 18 File and finish the saw - Cut surface of part 1 for a length of 300 mm.
- 19 Saw the corners for removing the unwanted metal for filing the radius.
- 20 File and finish two corners by radius filing on part 1.
- 21 Check the radius with a radius gauge.
- 22 File and finish the job with a second cut file within a tolerance of ± 0.5 mm (use outside calipers for checking).

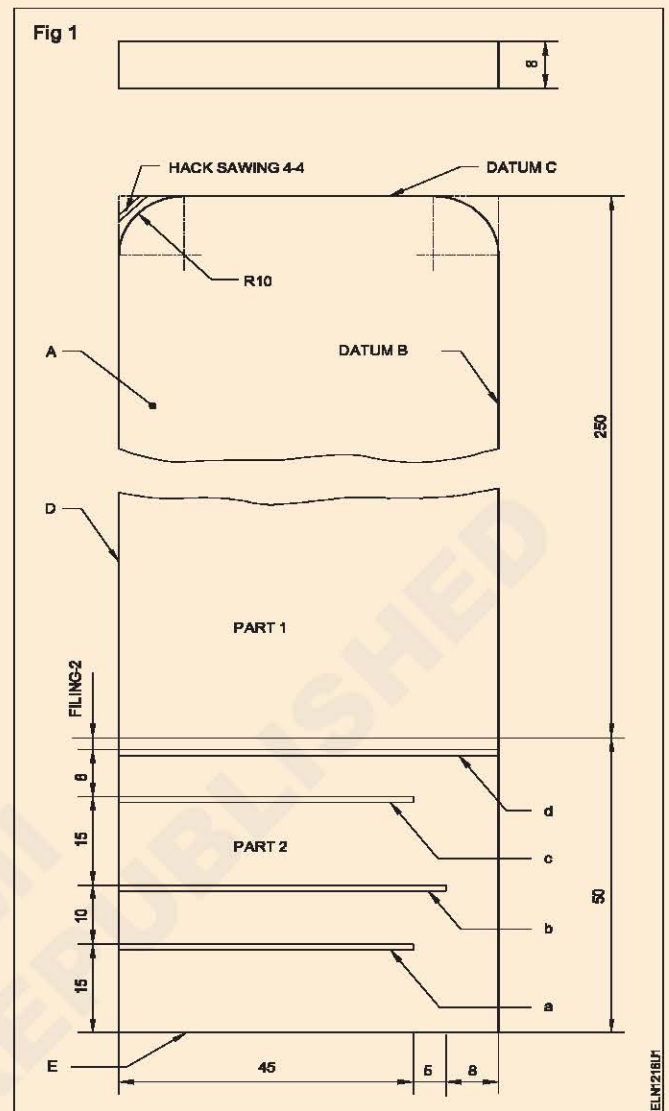

Skill sequence

Fixing of hacksaw blade on the frame and sawing

Objectives: This shall help you to

- fix the hacksaw blade on the frame
- practice sawing with dimensions.

The teeth of the blade should point from the handle.

- 1 Fix the blade to the frame in good tension. (Fig 1)

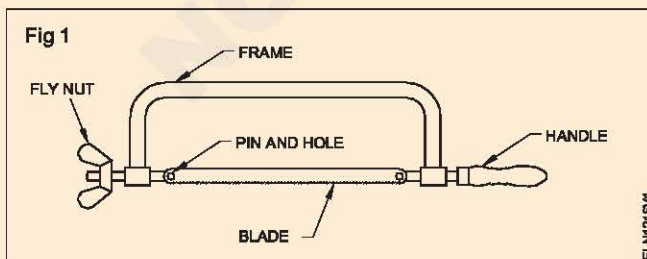

- 2 Set your thumb nail vertically to the location of the cut, and this location should be at least 10 mm from the vice. (Fig 2)
- 3 Hold and press the hacksaw straight. (Fig 3)

Fig 2

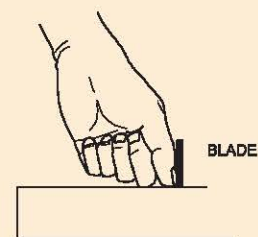

Do not use force when pulling back. Occasionally apply cutting compound while cutting.

Use the full length of the hacksaw blade.

- 4 Make the last few cuts holding the piece to be cut in your left hand. (Fig 4)

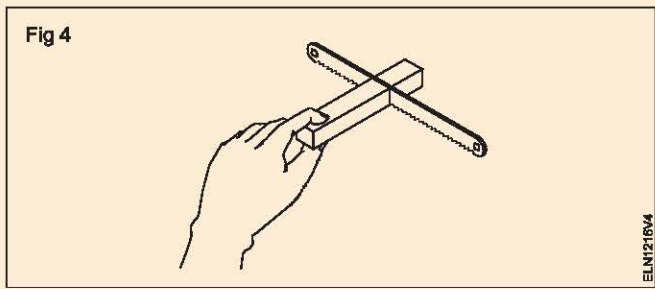
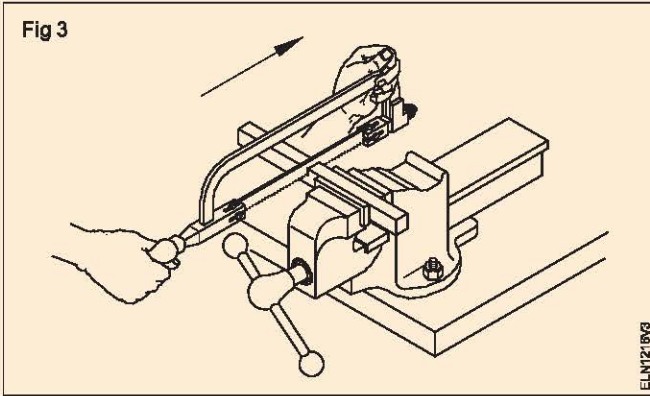

For this section use a fine grade blade. A minimum of two to three teeth should be in contact with the work. (Fig 5)

